

---

NO. T069-838

---

ISSUED: MAY 31, 2011

---

REVISED: JUN. 16, 2014

---



**HOSHIZAKI  
UNDERCOUNTER  
REFRIGERATOR/FREEZER**

**MODEL      RTC-M\_A series  
                  FTC-M\_A series**

**SERVICE MANUAL**

# CONTENTS

PAGE

I. GENERAL INFORMATION -----	1
1. SAFETY INSTRUCTIONS -----	1
2. DIMENSIONS/SPECIFICATIONS -----	3
[a] RTC-120MNA -----	3
[b] RTC-120MDA -----	4
[c] RTC-150MNA -----	5
[d] RTC-150MDA -----	6
[e] RTC-180MNA -----	7
[f] RTC-180MDA -----	8
[g] FTC-120MNA -----	9
[h] FTC-120MDA -----	10
[i] FTC-150MNA -----	11
[j] FTC-150MDA -----	12
[k] FTC-180MNA -----	13
[l] FTC-180MDA -----	14
II. TECHNICAL INFORMATION -----	15
1. WIRING DIAGRAM -----	15
[a] RTC SERIES -----	15
[b] FTC-120MNA, FTC-120MDA, FTC-150MNA -----	16
[c] FTC-150MDA, FTC-180MNA, FTC-180MDA -----	17
2. REFRIGERATION CIRCUIT -----	18
[a] RTC SERIES -----	18
[b] FTC SERIES -----	19
3. ELECTRONIC CONTROLS -----	20
[a] SET POINT TEMPERATURE -----	20
[b] CABINET TEMPERATURE DIFFERENTIAL -----	20
[c] DEFROST CYCLE -----	20
[d] DEFROST TERMINATION TEMPERATURE -----	20
[e] TEMPERATURE DISPLAY -----	20
[f] COMPRESSOR SOFT START -----	21
[g] HIGH PRESSURE SWITCH -----	21
[h] CHECKING SET POINT TEMPERATURE -----	22
[i] MANUAL DEFROST -----	22
[j] ERROR CODES -----	22
4. TIMING CHART -----	23
[a] STARTUP - CONTROL -----	23
[b] DEFROST -----	24
5. CONTROLLER -----	25
[a] RTC SERIES -----	25
[b] FTC SERIES -----	28
III. SERVICE DIAGNOSIS -----	33
1. ERROR CODES -----	33
2. FLOWCHART -----	34
[a] RTC SERIES -----	34
[b] FTC SERIES -----	36

3. COMPONENTS -----	38
4. CONTROLLER -----	40
[a] SERVICING CONTROLLER-----	40
[b] CHECKING THERMISTOR-----	41
IV. REMOVAL AND REPLACEMENT OF COMPONENTS -----	42
1. REFRIGERATION CIRCUIT -----	42
[a] REFRIGERANT -----	42
[b] COMPRESSOR-----	42
[c] CONDENSER -----	44
[d] DRIER -----	44
[e] EVAPORATOR -----	44
2. ELECTRICAL PARTS-----	45
[a] CONDENSER FAN MOTOR-----	45
[b] INTERIOR FAN MOTOR -----	46
[c] DEFROST HEATER, THERMAL FUSE-----	47
[d] INTERIOR THERMISTOR, DEFROST THERMISTOR-----	48
[e] CONTROLLER-----	49
[f] FUSE -----	49
[g] FORCED DRAIN WATER EVAPORATION PAN -----	49
3. DOOR GASKET-----	50
[a] REMOVAL -----	50
[b] REPLACEMENT -----	50

# I. GENERAL INFORMATION

## 1. SAFETY INSTRUCTIONS

The following instructions contain important safety precautions and should be strictly observed. The terms used here are defined as follows:

**WARNING:** There is a possibility of death or serious injury to the service person and a third party or the user due to improper service operations or defects in serviced products.

**CAUTION:** There is a possibility of injury to the service person and a third party or the user or damage to their property\* due to improper service operations or defects in serviced products.

\* The term "damage to their property" here refers to extensive damage to household effects, houses and pets.

### WARNING

1. Always ask the user to keep children away from the work area. They may be injured by tools or disassembled products.
2. When there is no need to energize the unit during disassembly or cleaning, be sure to unplug the unit or disconnect the main power supply before servicing the unit to prevent electric shocks.
3. If the unit must be energized for inspection of the electric circuit, use rubber gloves to avoid contact with any live parts resulting in electric shocks.
4. Keep the following in mind when servicing the refrigeration circuit:
  - (1) Be sure to recover the refrigerant. Do not discharge it into the atmosphere. It will affect the environment.
  - (2) Check for any flames in the vicinity, and ensure good ventilation.
  - (3) If the refrigerant should leak in servicing, immediately put out any fire used in the vicinity.
  - (4) When unbrazing the refrigeration circuit connections, check that the circuit is completely evacuated. The refrigerant may produce a poisonous gas when coming in contact with an open flame.
  - (5) Do not braze in an enclosed room to prevent carbon monoxide poisoning.
  - (6) In case of a refrigerant leak, locate and repair the leaking part completely before recharging the refrigerant and checking for further leaks. If the leaking part cannot

be located, be sure to check again for further leaks after recharging the refrigerant. Leaked refrigerant may produce a poisonous gas when coming in contact with an open flame of a gas cooking stove or a fan heater.

- (7) Before servicing, check the surface temperature of the refrigeration circuit to prevent a burn.

5. Keep the following in mind when making electrical connections:

- (1) Check for proper earth connections, and repair if necessary to prevent electric shocks.
- (2) Always use service parts intended for the applicable model for replacement of defective parts. Use proper tools to secure the wiring. Otherwise abnormal operation or trouble may occur and cause electric leaks or fire.
- (3) Check for proper part installations, wiring conditions and soldered or solderless terminal connections to avoid fire, heat or electric shocks.
- (4) Be sure to replace damaged or deteriorated power cords and lead wires to prevent fire, heat or electric shocks.
- (5) Cut-off lead wires must be bound using closed end connectors or the like, with their closed ends up to avoid entrance of moisture that could lead to electric leaks or fire.
- (6) After servicing, always use a megohmmeter (500V DC) to check for the insulation resistance of at least 1 megohm between the live part (attachment plug) and the dead metal part (earth terminal).
- (7) Do not service the electrical parts with wet hands to prevent electric shocks.
- (8) The capacitors used for the compressor and other components may be under high voltage and should be discharged properly before servicing.

## **CAUTION**

1. After servicing, follow the instructions below:

- (1) Always check the unit for proper operation before finishing services.
- (2) Be sure to reassemble the parts completely. Loose assembly of such parts as control box cover may cause entrance of vermins resulting in a short circuit between terminals and possible ignition.

# 2. DIMENSIONS/SPECIFICATIONS

## [a] RTC-120MNA

ITEM	Hashizaki Undercounter Refrigerator
MODEL	RTC-120MNA
POWER SUPPLY	1 Phase 220-240V 50Hz Capacity:0.50kVA(2.27A)
AMPERAGE	Rated 1.6A
ELECTRIC CONSUMPTION	Motor: 215W(Power Factor:61%) Heater: 18W Refrigeration: 235W Defrost: 22W
HEAT REJECTION	350W
POWER CORD	2.3m (Plug with Earth Wire)
EFFECTIVE CAPACITY	231L
OUTSIDE DIMENSIONS	1200mm(W)×750mm(D)×800(790-830)mm(H)
INSIDE DIMENSIONS	830mm(W)×577mm(D)×588mm(H)
EXTERIOR	Precoated Steel, Galvanized Steel (Rear/Bottom) ABS Plastic (Front Panel)
INTERIOR	Precoated Steel, ABS Plastic (Door)
INSULATION	Polyurethane Foam
INSULATION FOAM BLOWING AGENT	Cyclopentane
REFRIGERATION SYSTEM	Forced Air Circulation
DEFROST SYSTEM	Off Cycle
COMPRESSOR	Hermetic 280W (cooling capacity)
CONDENSER	Fin and Tube type, Air-cooled
EVAPORATOR	Fin and Tube Type
REFRIGERANT	R134a/90g
TEMPERATURE CONTROL	Microprocessor controlled Adjustable from -2 to 12°C
DEFROST CONTROL	Microprocessor controlled
ELECTRIC CIRCUIT PROTECTION	Fuse, Earth Wire
COMPRESSOR PROTECTION	Motor Protector
LEG	Plastic Adjustable 90 to 130mm
SHELF	4pcs. (include Bottom shelf)
WEIGHT	Net: 67kg (Gross: Approx. 72kg)
PACKAGE	Carton 1265mm(W)×830mm(D)×790mm(H)
ACCESSORIES	Drain Hose x 1(φ 26mm OD), Cable strap x 3
OPERATING CONDITIONS	Ambient Temperature:5-38°C Voltage Range:Rated Voltage±6%

- \* We reserve the right to make changes in specifications and design without prior notice.
1. Install the product properly in accordance with the instructions on location, electrical connections stated in the instruction manual provided.  
Allow 10mm extra space at the installation site to meet any installation requirements(additional spacing is also required for proper air flow and pipe connections).
  2. The heat rejection is based on the reached pull-down temperature at ambient temperature of 38°C and power supply of 220V 50Hz.  
The amperage and electric consumption are based on measurements at ambient temperature of 38°C and power supply of 220V 50Hz.
  3. The cabinet temperature range of -2 to 12°C is guaranteed at ambient temperature of 30°C.
  4. Product code: T069

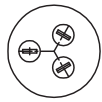

PLUG SHAPE

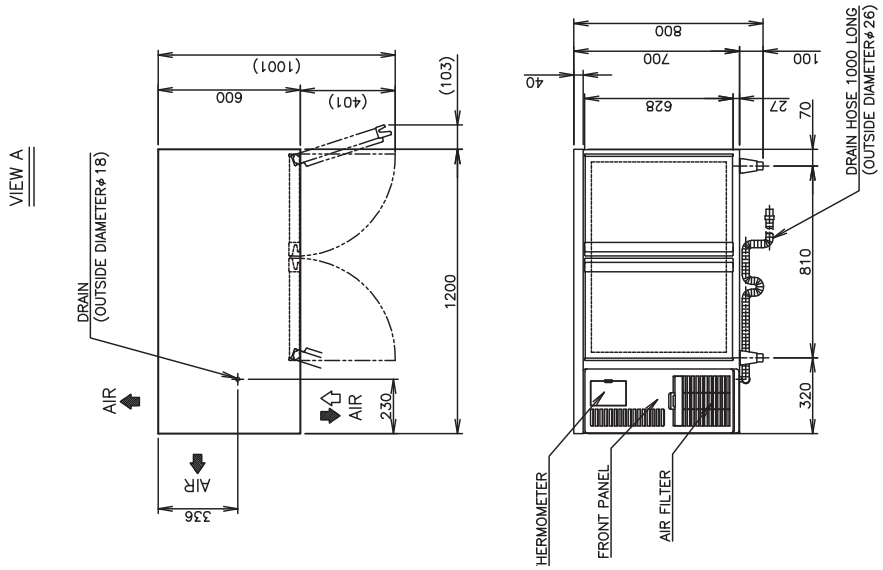
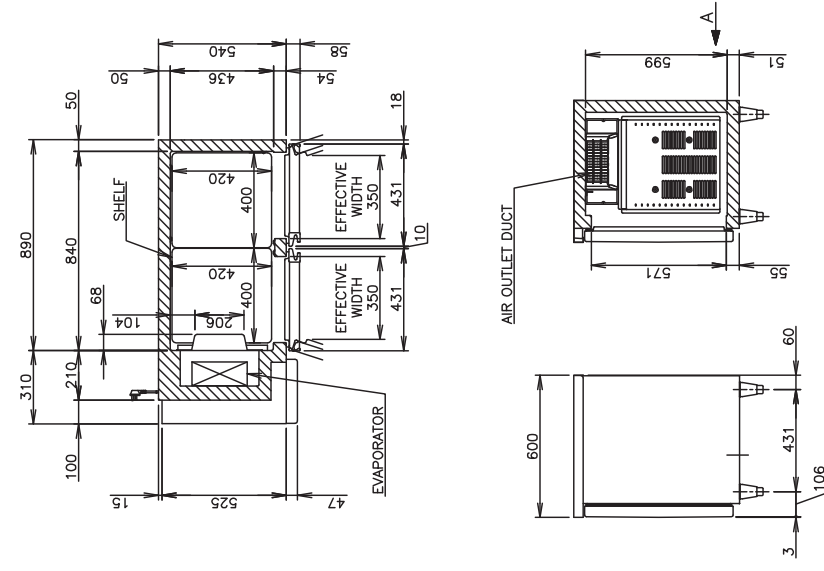
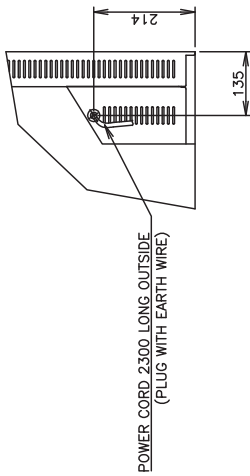

# [b] RTC-120MDA

ITEM	Hoshizaki Undercounter Refrigerator
MODEL	RTC-120MDA
POWER SUPPLY	1 Phase 220-240V 50Hz Capacity:0.5kVA(2.27A)
AMPERAGE	Rated 1.6A
ELECTRIC CONSUMPTION	Motor 215W(Power Factor61%) Heater 18W Refrigeration 235W Defrost 22W
HEAT REJECTION	350W
POWER CORD	2.3m (Plug with Earth Wire)
EFFECTIVE CAPACITY	307L
OUTSIDE DIMENSIONS	1200mm(W)×750mm(D)×800(790-830)mm(H)
INSIDE DIMENSIONS	840mm(W)×586mm(D)×588mm(H)
EXTERIOR	Precast Steel, Galvanized Steel (Rear/Bottom) ABS Plastic (Front Panel)
INTERIOR	Precast Steel, ABS Plastic (Door)
INSULATION	Polyurethane Foam
INSULATION FOAM BLOWING AGENT	Cyclopentane
REFRIGERATION SYSTEM	Forced Air Circulation
DEFROST SYSTEM	Off Cycle
COMPRESSOR	Hermetic 280W (cooling capacity)
CONDENSER	Fin and Tube type, Air-cooled
EVAPORATOR	Fin and Tube Type
REFRIGERANT	R134a/90g
TEMPERATURE CONTROL	Microprocessor controlled Adjustable from -2 to 12°C
DEFROST CONTROL	Microprocessor controlled
ELECTRIC SAFETY PROTECTION	Fuse, Earth Wire
COMPRESSOR PROTECTION	Motor Protector
LEG	Plastic Adjustable 90 to 130mm
SHELF	4pcs. (include Bottom shelf)
WEIGHT	Net: 73kg (Gross: Approx. 78kg)
PACKAGE	Carton 1265mm(W)×830mm(D)×790mm(H)
ACCESSORIES	Drain Hose x 1(φ26mm OD), Cable strap x 3
OPERATING CONDITIONS	Ambient Temperature:5-38°C Voltage Range:Rated Voltage±6%

- We reserve the right to make changes in specifications and design without prior notice.
1. Install the product properly in accordance with the instructions on location, electrical connections stated in the instruction manual provided. Allow 10mm extra space at the installation site to meet any installation requirements (additional spacing is also required for proper air flow and pipe connections).
  2. The heat rejection is based on the reached pull-down temperature at ambient temperature of 38°C and power supply of 220V 50Hz. The ampere and electric consumption are based on measurements at ambient temperature of 38°C and power supply of 220V 50Hz.
  3. The cabinet temperature range of -2 to 12°C is guaranteed at ambient temperature of 30°C.
  4. Product code: 1072

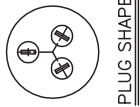

PLUG SHAPE

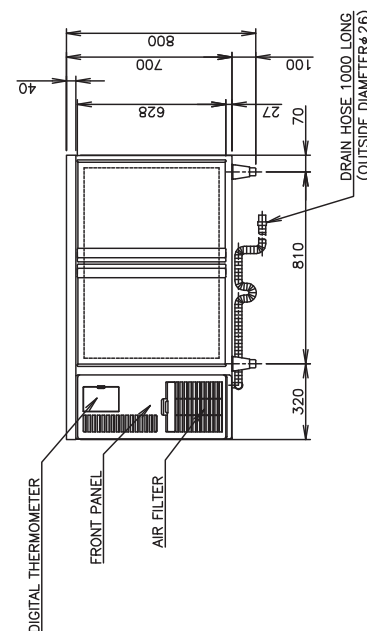
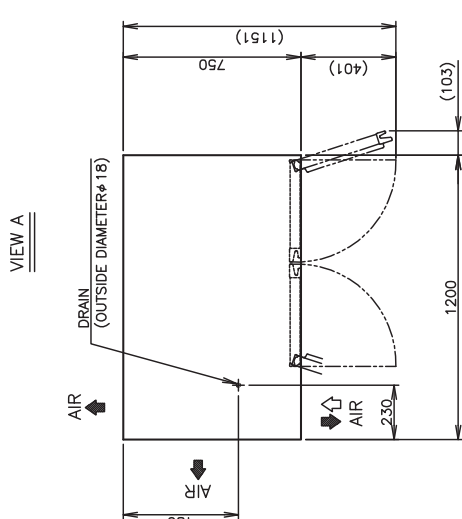
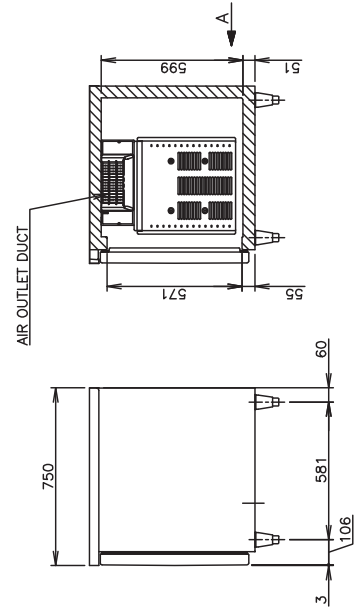
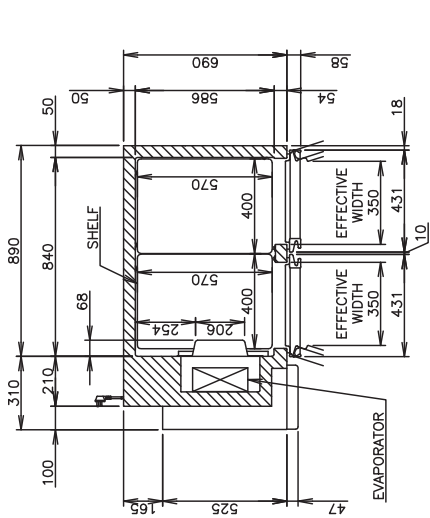
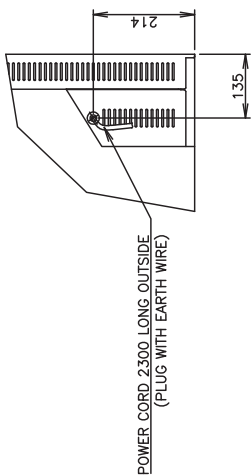

# [c] RTC-150MNA

ITEM	Hoshizaki Undercounter Freezer
MODEL	FTC-150MNA
POWER SUPPLY	1 Phase 220-240V 50Hz Capacity:0.95kVA(4.3A)
AMPERAGE	Rated 3.0A
ELECTRIC CONSUMPTION	Motor 415W(Power Factor65%) Heater 344W Refrigeration 457W Defrost 344W
HEAT REJECTION	650W
POWER CORD	2.3m (Plug with Earth Wire)
EFFECTIVE CAPACITY	318L
OUTSIDE DIMENSIONS	1500mm(W)×600mm(D)×800(790-830)mm(H)
INSIDE DIMENSIONS	1140mm(W)×436mm(D)×599mm(H)
EXTERIOR	Precoated Steel, Galvanized Steel (Rear/Bottom) ABS Plastic (Front Panel)
INTERIOR	Precoated Steel, ABS Plastic (Door)
INSULATION	Polyurethane Foam
INSULATION FOAM	Cyclopentane
BLOWING AGENT	
REFRIGERATION SYSTEM	Forced Air Circulation
DEFROST SYSTEM	Glass Tube Heater
COMPRESSOR	Hermetic 410W (cooling capacity)
CONDENSER	Fin and Tube type, Air-cooled
EVAPORATOR	Fin and Tube Type
REFRIGERANT	R404A/160g
TEMPERATURE CONTROL	Microprocessor controlled Adjustable from -23 to -7C
DEFROST CONTROL	Microprocessor controlled
ELECTRIC CIRCUIT PROTECTION	Fuse, Earth Wire
COMPRESSOR PROTECTION	Motor Protector
LEG	Plastic Adjustable 90 to 130mm
SHELF	4pcs. (include Bottom shelf)
WEIGHT	Net: 86kg (Gross: Approx. 91kg)
PACKAGE	Carton 1565mm(W)×680mm(D)×790mm(H)
ACCESSORIES	Drain Hose x 1(φ 26mm OD), Cable strap x 3
OPERATING CONDITIONS	Ambient Temperature:5-38C Voltage Range:Rated Voltage±6%

\* We reserve the right to make changes in specifications and design without prior notice.

1. Install the product properly in accordance with the instructions on location, electrical connections stated in the instruction manual provided.  
Allow 10mm extra space at the installation site to meet any installation requirements (additional spacing is also required for proper air flow and pipe connections).
2. The heat rejection is based on the reached pull-down temperature at ambient temperature of 35C and power supply of 220V 50Hz.  
The amperage and electric consumption are based on measurements at ambient temperature of 38C and power supply of 220V 50Hz.
3. The cabinet temperature range of -23 to -7C is guaranteed at ambient temperature of 50C.
4. Product code: T076

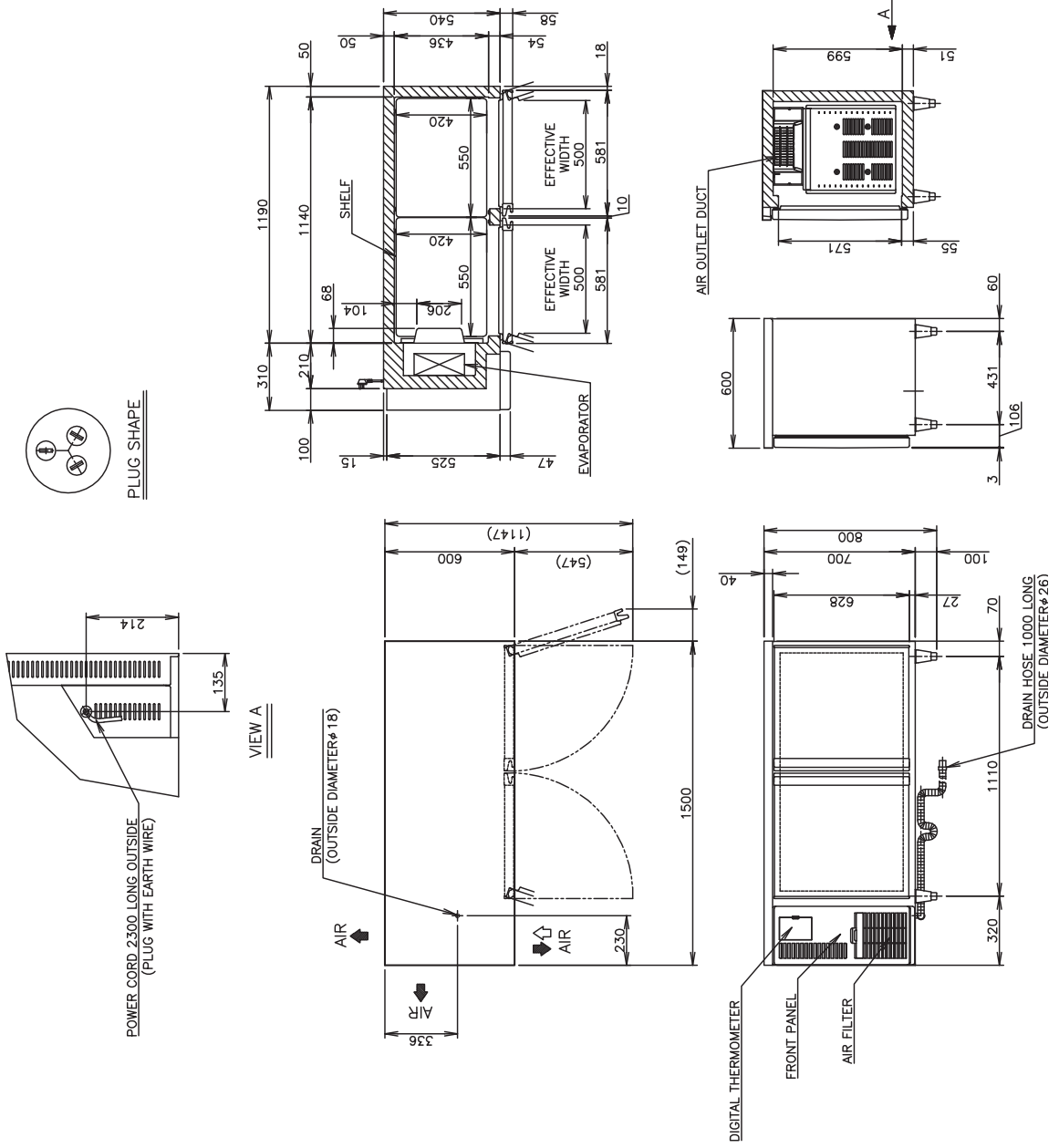



# [d] RTC-150MDA

ITEM	Hoshizaki Undercounter Refrigerator
MODEL	RTC-150MDA
POWER SUPPLY	1 Phase 220-240V 50Hz Capacity:0.5kVA(2.27A)
AMPERAGE	Rated 1.6A
ELECTRIC CONSUMPTION	Motor 235W(Power Factor66%) Heater 21W Refrigeration 255W Defrost 25W
HEAT REJECTION	360W
POWER CORD	2.3m (Plug with Earth Wire)
EFFECTIVE CAPACITY	420L
OUTSIDE DIMENSIONS	1500mm(W)×750mm(D)×800(790-830)mm(H)
INSIDE DIMENSIONS	1140mm(W)×568mm(D)×599mm(H)
EXTERIOR	Precoated Steel, Galvanized Steel (Rear/Bottom)
INTERIOR	Precoated Steel, ABS Plastic (Door)
INSULATION	Polyurethane Foam
INSULATION FOAM BLOWING AGENT	Cyclopentane
REFRIGERATION SYSTEM	Forced Air Circulation
DEFROST SYSTEM	Off Cycle
COMPRESSOR	Hermetic 280W (cooling capacity)
CONDENSER	Fin and Tube type, Air-cooled
EVAPORATOR	Fin and Tube Type
REFRIGERANT	R134a/90g
TEMPERATURE CONTROL	Microprocessor controlled Adjustable from -2 to 12°C
DEFROST CONTROL	Microprocessor controlled
ELECTRIC CIRCUIT PROTECTION	Fuse, Earth Wire
COMPRESSOR PROTECTION	Motor Protector
LEG	Plastic Adjustable 90 to 130mm
SHELF	4 pcs. (include Bottom shelf)
WEIGHT	Net:87kg (Gross: Approx. 92kg)
PACKAGE	Carton 1565mm(W)×830mm(D)×790mm(H)
ACCESSORIES	Drain Hose 1(φ26mm OD), Cable strap×3
OPERATING CONDITIONS	Ambient Temperature:5-38°C Voltage Range:Rated Voltage±6%

\*We reserve the right to make changes in specifications and design without prior notice.

1. Install the product properly in accordance with the instructions on location, electrical connections stated in the instruction manual provided.  
Allow 10mm extra space at the installation site to meet any installation requirements(additional pipe connections).
2. The heat rejection is based on the reached pull-down temperature at ambient temperature of 38°C and power supply of 220V 50Hz.  
The amperage and electric consumption are based on measurements at ambient temperature of 38°C and power supply of 220V 50Hz.
3. The cabinet temperature range of -2 to 12°C is guaranteed at ambient temperature of 30°C.
4. Product code: T073

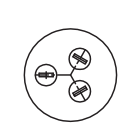

PLUG SHAPE

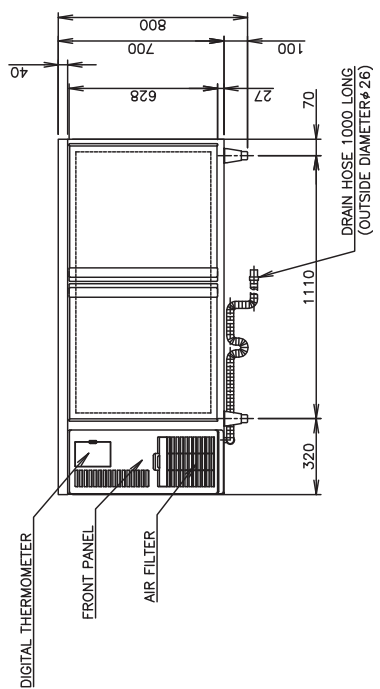
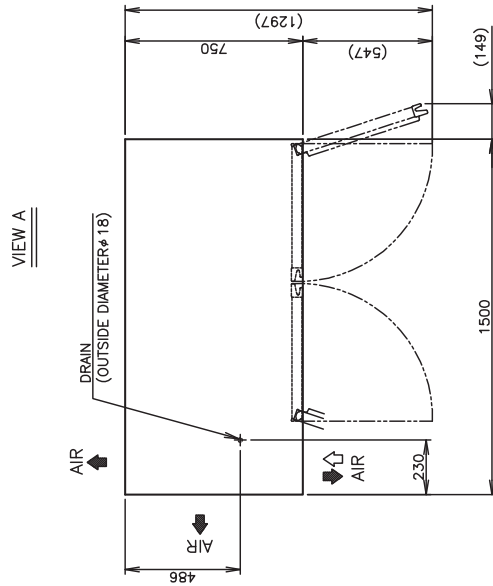
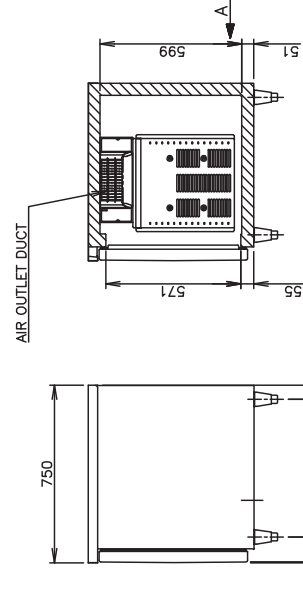
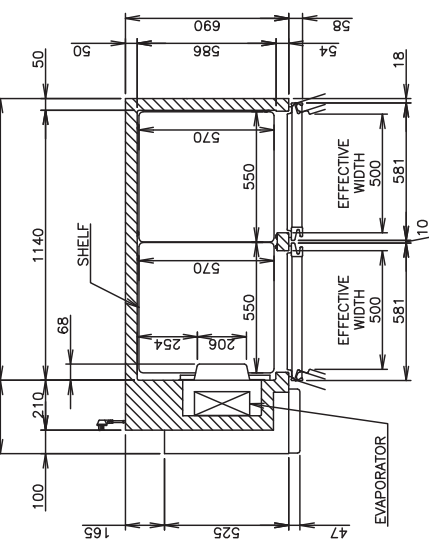
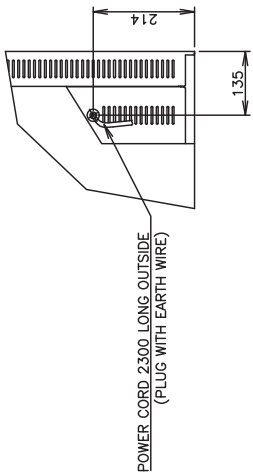

# [e] RTC-180MNA

ITEM	Hoshizaki Undercounter Refrigerator
MODEL	RTC-180MNA
POWER SUPPLY	1 Phase 220-240V 50Hz Capacity:0.5kVA(2.27A)
AMPERAGE	Rated 1.6A
ELECTRIC CONSUMPTION	Motor 225W(Power Factor63%) Heater 29W Refrigeration 255W Defrost 33W
HEAT REJECTION	380W
POWER CORD	2.3m (Plug with Earth Wire)
EFFECTIVE CAPACITY	40.1L
OUTSIDE DIMENSIONS	1800mm(W)×600mm(D)×800(790-830)mm(H)
INSIDE DIMENSIONS	1440mm(W)×436mm(D)×599mm(H)
EXTERIOR	Precoated Steel, Galvanized Steel (Rear/Bottom) ABS Plastic (Front Panel)
INTERIOR	Precoated Steel, ABS Plastic (Door)
INSULATION	Polyurethane Foam
INSULATION FOAM BLOWING AGENT	Cyclopentane
REFRIGERATION SYSTEM	Forced Air Circulation
DEFROST SYSTEM	Off Cycle
COMPRESSOR	Hermetic 280W (cooling capacity)
CONDENSER	Fin and Tube Type, Air-cooled
EVAPORATOR	Fin and Tube Type
REFRIGERANT	R134a/110g
TEMPERATURE CONTROL	Microprocessor controlled Adjustable from -2 to 12°C
DEFROST CONTROL	Microprocessor controlled
ELECTRIC CIRCUIT PROTECTION	Fuse, Earth Wire
COMPRESSOR PROTECTION	Motor Protector
LEG	Plastic Adjustable 90 to 130mm
SHELF	6pcs. (include Bottom shelf)
WEIGHT	Net:93kg (Gross: Approx. 99kg)
PACKAGE	Carton 1865mm(W)×680mm(D)×790mm(H)
ACCESSORIES	Drain Hose x 1 (φ26mm OD), Cable strap x 3
OPERATING CONDITIONS	Ambient Temperature:5-38°C Voltage Range:Rated Voltage±6%

- \*We reserve the right to make changes in specifications and design without prior notice.
1. Install the product properly in accordance with the instructions on location, electrical connections stated in the instruction manual provided. Allow 10mm extra space at the installation site to meet any installation requirements (additional spacing is also required for proper air flow), pipe connections).
  2. The heat rejection is based on the reached pull-down temperature at ambient temperature of 38°C and power supply of 220V 50Hz. The amperage and electric consumption are based on measurements at ambient temperature of 38°C and power supply of 220V 50Hz.
  3. The cabinet temperature range of -2 to 12°C is guaranteed at ambient temperature of 30°C.
  4. Product code: T071

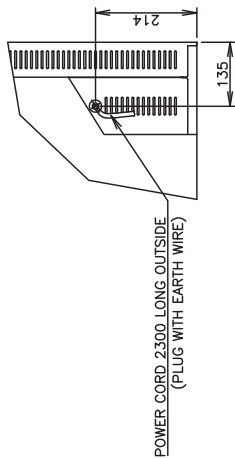

PLUG SHAPE

VIEW A(1/10)

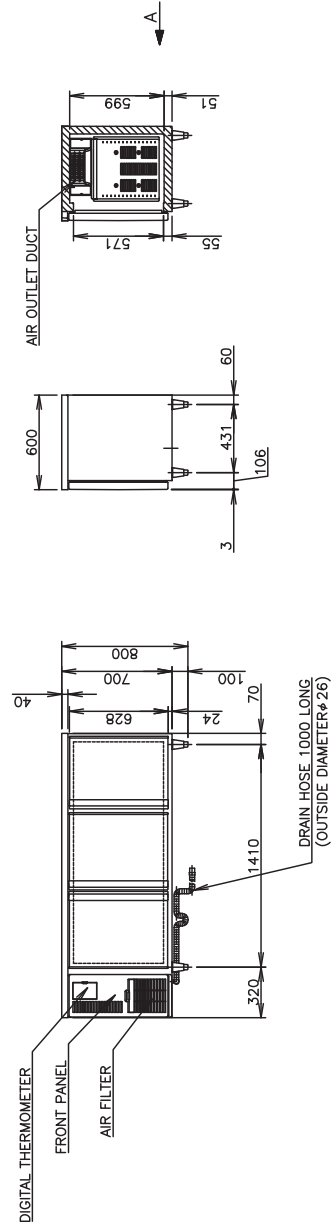
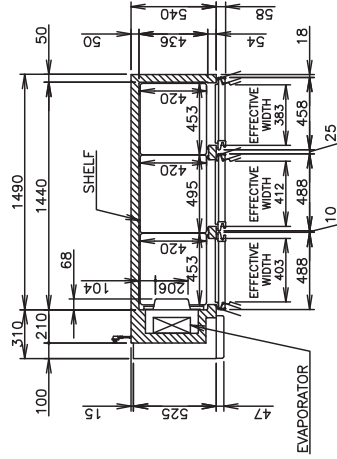

# [f] RTC-180MDA

ITEM	Hoshizaki Undercounter Refrigerator
MODEL	RTC-180MDA
POWER SUPPLY	1 Phase 220-240V 50Hz Capacity:0.5kVA(2.27A)
AMPERAGE	Rated 1.6A
ELECTRIC CONSUMPTION	Motor 225W(Power Factor63%) Heater 29W Refrigeration 255W Defrost 33W
HEAT REJECTION	380W
POWER CORD	2.3m (Plug with Earth Wire)
EFFECTIVE CAPACITY	530L
OUTSIDE DIMENSIONS	1800mm(W)×750mm(D)×800(790-830)mm(H)
INSIDE DIMENSIONS	1440mm(W)×586mm(D)×599mm(H)
EXTERIOR	Precoated Steel, Galvanized Steel (Rear/Bottom) ABS Plastic (Front Panel)
INTERIOR	Precoated Steel, ABS Plastic (Door)
INSULATION	Polyurethane Foam
INSULATION FOAM BLOWING AGENT	Cyclopentane
REFRIGERATION SYSTEM	Forced Air Circulation
DEFROST SYSTEM	Off Cycle
COMPRESSOR	Hermetic 280W (cooling capacity)
CONDENSER	Fin and Tube type, Air-cooled
EVAPORATOR	Fin and Tube Type
REFRIGERANT	R134a/110g
TEMPERATURE CONTROL	Microprocessor controlled Adjustable from -2 to 12°C
DEFROST CONTROL	Microprocessor controlled
ELECTRIC PROTECTION	Fuse, Earth Wire
COMPRESSOR PROTECTION	Motor Protector
LEG	Plastic Adjustable 90 to 130mm
SHELF	6pcs. (include Bottom shelf)
WEIGHT	Net:101kg (Gross: Approx. 107kg)
PACKAGE	Carton 1865mm(W)×830mm(D)×790mm(H)
ACCESSORIES	Drain Hose x 1(φ26mm OD), Cable strap x 3
OPERATING CONDITIONS	Ambient Temperature:-38°C Voltage Range:Rated Voltage±6%

- \* We reserve the right to make changes in specifications and design without prior notice.
1. Install the product properly in accordance with the instructions on location, electrical connections stated in the instruction manual provided. Allow 10mm extra space at the installation site to meet any installation requirements(additional spacing is also required for proper air flow).
  2. The heat rejection is based on the reached pull-down temperature at ambient temperature of 38°C and power supply of 220V 50Hz. The ampere and electric consumption are based on measurements at ambient temperature of 40°C and power supply of 220V 50Hz.
  3. The cabinet temperature range of -2 to 12°C is guaranteed at ambient temperature of 30°C.
  4. Product code: T074

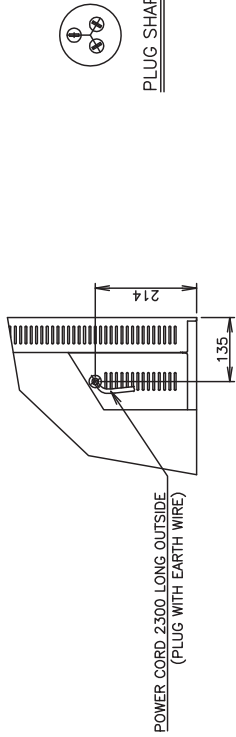

PLUG SHAPE

VIEW A(1/10)

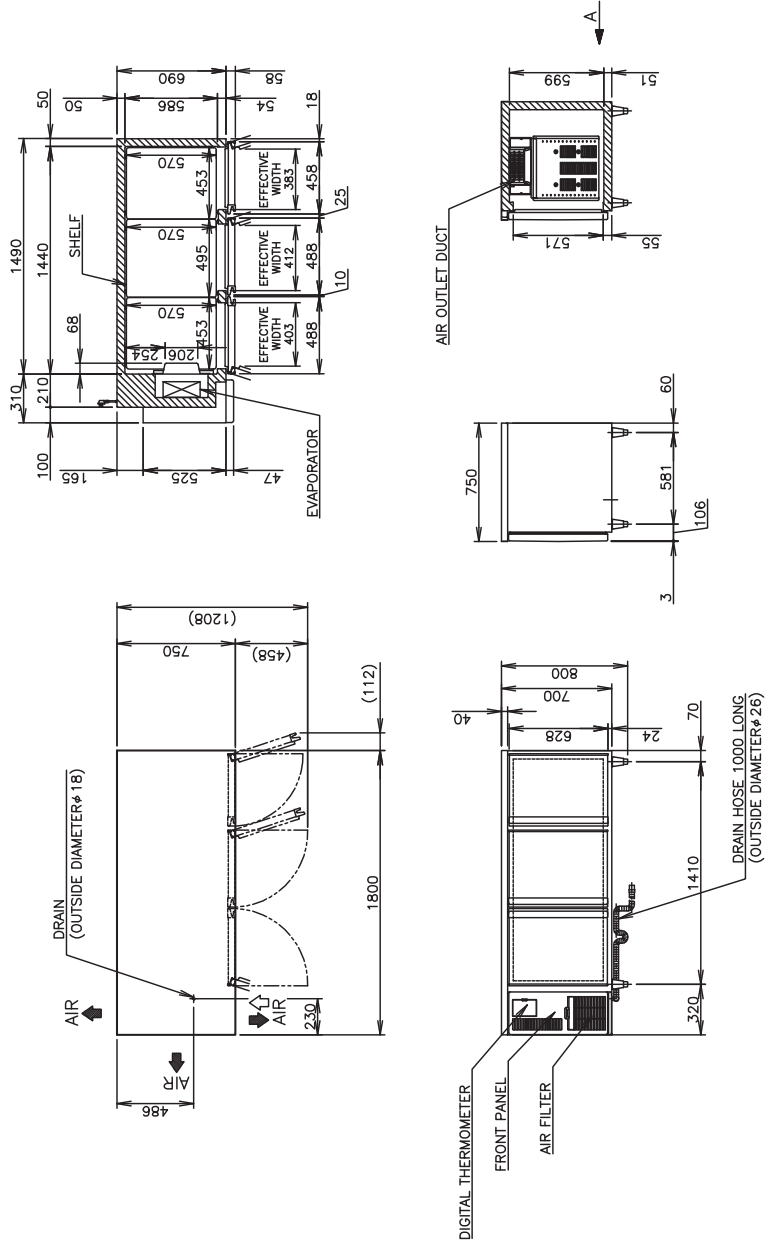

# [g] FTC-120MNA

ITEM	Hoshizaki Undercounter Freezer
MODEL	FTC-120MNA
POWER SUPPLY	1 Phase 220-240V 50Hz Capacity:0.95kVA(4.3A)
AMPERAGE	Rated 2.9A
ELECTRIC CONSUMPTION	Motor 410W(Power Factor66%) Heater 339W Refrigeration 447W Defrost 339W
HEAT REJECTION	650W
POWER CORD	2.3m (Plug with Earth Wire)
EFFECTIVE CAPACITY	231L
OUTSIDE DIMENSIONS	1200(W)×600(D)×H800(790-830)mm(H)
INSIDE DIMENSIONS	840mm(W)×436mm(D)×599mm(H)
EXTERIOR	Precoated Steel, Galvanized Steel (Rear/Bottom) ABS Plastic (Front Panel)
INTERIOR	Precoated Steel, ABS Plastic (Door)
INSULATION	Polyurethane Foam
INSULATION FOAM	Cyclopentane
BLOWING AGENT	Forced Air Circulation
REFRIGERATION SYSTEM	Glass Tube Heater
DEFROST SYSTEM	Hermetic 410W (cooling capacity)
COMPRESSOR	Fin and Tube type, Air-cooled
CONDENSER	Fin and Tube Type
EVAPORATOR	R404A/160g
REFRIGERANT	Microprocessor controlled Adjustable from -23 to -7℃
TEMPERATURE CONTROL	Microprocessor controlled
DEFROST CONTROL	Fuse, Earth Wire
ELECTRIC CIRCUIT PROTECTION	Motor Protector
COMPRESSOR PROTECTION	Plastic Adjustable 90 to 130mm
LEG	4pcs. (include Bottom shelf)
SHELF	Net: 72kg (Gross: Approx. 77kg)
WEIGHT	Carton 1265mm(W)×680mm(D)×790mm(H)
PACKAGE	Drain Hose x 1(φ26mm OD), Cable strap x 3
ACCESSORIES	Ambient Temperature:5-38℃ Voltage Range:Rated Voltage±6%
OPERATING CONDITIONS	

- \* We reserve the right to make changes in specifications and design without prior notice.
1. Install the product properly in accordance with the instructions on location, electrical connections stated in the instruction manual provided.  
Allow 10mm extra space at the installation site to meet any installation requirements(Additional spacing is also required for proper air flow and pipe connections).
  2. The heat rejection is based on the reached pull-down temperature at ambient temperature of 35℃ and power supply of 220V 50Hz.  
The amperage and electric consumption are based on measurements at ambient temperature of 38℃ and power supply of 220V 50Hz.
  3. The cabinet temperature range of -23 to -7℃ is guaranteed at ambient temperature of 30℃.
  4. Product code: 1075

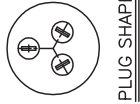

PLUG SHAPE

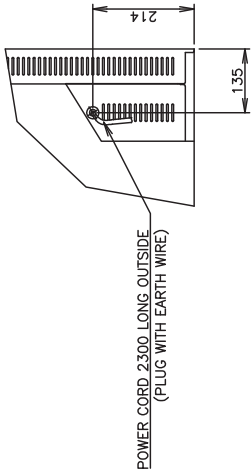

VIEW A

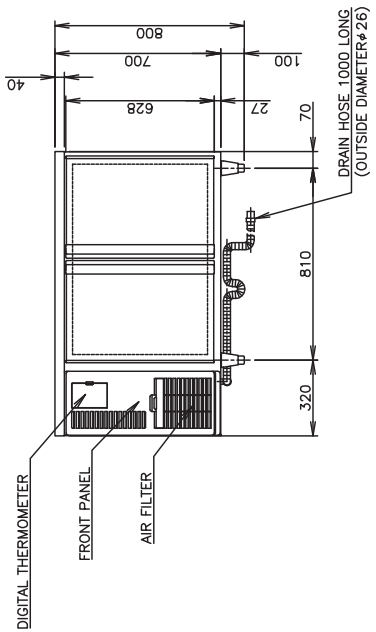
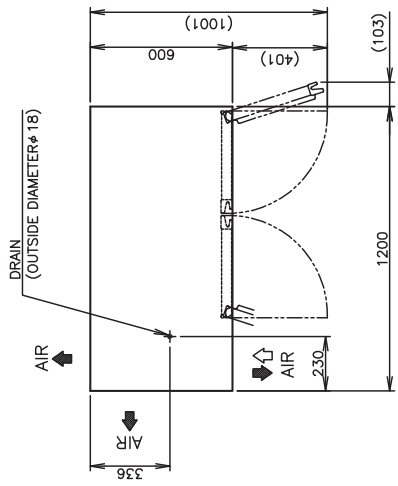
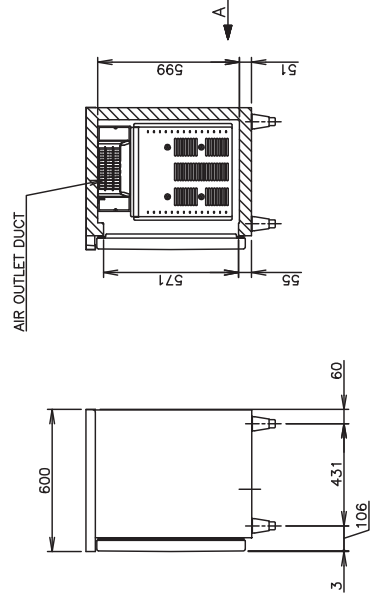
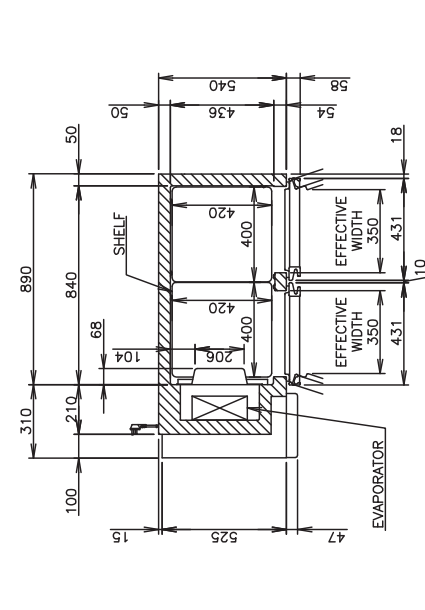

# [h] FTC-120MDA

ITEM	Hoshizaki Undercounter Freezer
MODEL	FTC-120MDA
POWER SUPPLY	1 Phase 220-240V 50Hz Capacity:0.95kVA(4.3A)
AMPERAGE	Rated 2.9A
ELECTRIC CONSUMPTION	Motor 410W(Power Factor66%) Heater 339W Refrigeration 447W Defrost 339W
HEAT REJECTION	650W
POWER CORD	2.3m (Plug with Earth Wire)
EFFECTIVE CAPACITY	307L
OUTSIDE DIMENSIONS	1200mm(W)×750mm(D)×800(790-830)mm(H)
INSIDE DIMENSIONS	840mm(W)×586mm(D)×588mm(H)
EXTERIOR	Precoated Steel, Galvanized Steel (Rear/Bottom) ABS Plastic (Front Panel)
INTERIOR	Precoated Steel, ABS Plastic (Door)
INSULATION	Polyurethane Foam
INSULATION FOAM BLOWING AGENT	Cyclopentane
REFRIGERATION SYSTEM	Forced Air Circulation
DEFROST SYSTEM	Glass Tube Heater
COMPRESSOR	Hermetic 4.10W (cooling capacity)
CONDENSER	Fin and Tube type, Air-cooled
EVAPORATOR	Fin and Tube Type
REFRIGERANT	R404A/160g
TEMPERATURE CONTROL	Microprocessor controlled Adjustable from -23 to -7℃
DEFROST CONTROL	Microprocessor controlled
ELECTRIC CIRCUIT PROTECTION	Fuse, Earth Wire
COMPRESSOR PROTECTION	Motor Protector
LEG	Plastic Adjustable 90 to 130mm
SHELF	4 pcs. (include Bottom shelf)
WEIGHT	Net: 78kg (Gross: Approx. 83kg)
PACKAGE	Carton 1265mm(W)×850mm(D)×790mm(H)
ACCESSORIES	Drain Hose x 1(φ26mm OD), Cable strap x 3
OPERATING CONDITIONS	Ambient Temperature:-3℃ Voltage Range:Rated Voltage±6%

- We reserve the right to make changes in specifications and design without prior notice.
1. Install the product properly in accordance with the instructions on location, electrical connections stated in the instruction manual provided.  
Allow 10mm extra space at the installation site to meet any installation requirements(additional spacing is also required for proper air flow and pipe connections).
  2. The heat rejection is based on the reached pull-down temperature at ambient temperature of 35℃ and power supply of 220V 50Hz.  
The amperage and electric consumption are based on measurements at ambient temperature of 38℃ and power supply of 220V 50Hz.
  3. The cabinet temperature range of -23 to -7℃ is guaranteed at ambient temperature of 30℃.
  4. Product code: T078

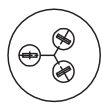

PLUG SHAPE

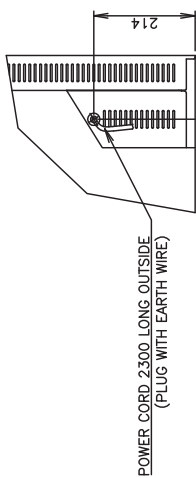

POWER CORD 2,300 LONG OUTSIDE (PLUG WITH EARTH WIRE)

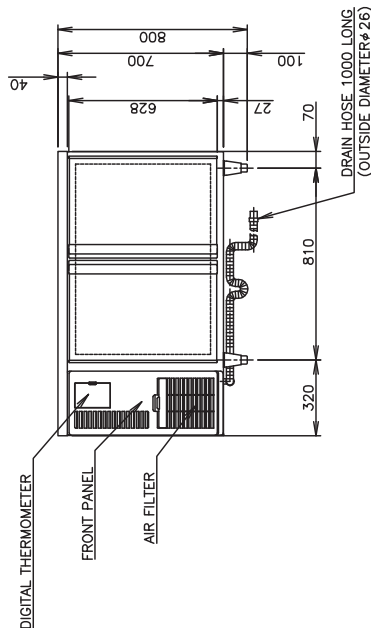
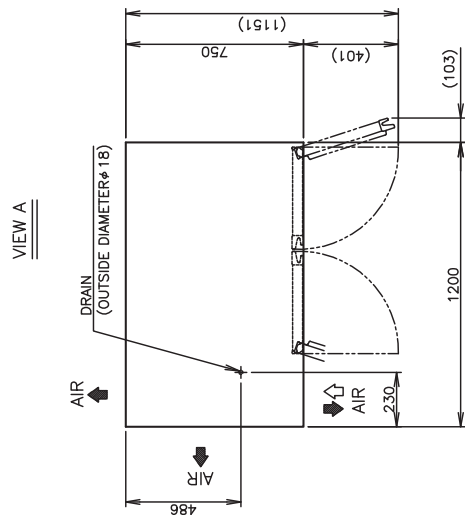
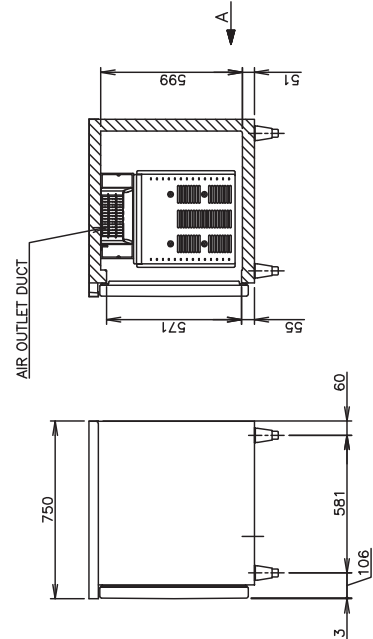
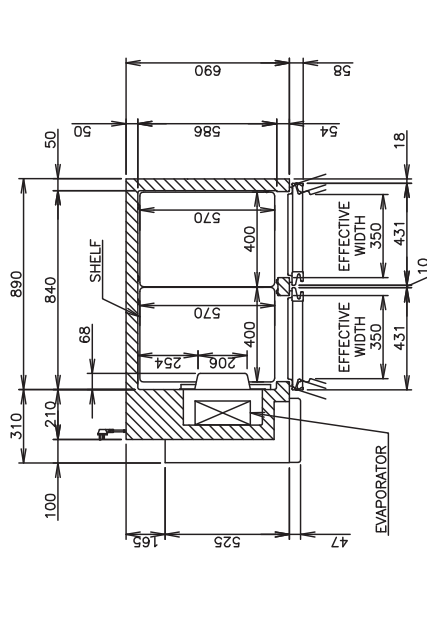

# [i] FTC-150MNA

ITEM	Hoshizaki Undercounter Freezer
MODEL	FTC-150MNA
POWER SUPPLY	1 Phase 220-240V 50Hz Capacity:0.95kVA(4.3A)
AMPERAGE	Rated 3.0A
ELECTRIC CONSUMPTION	Motor 415W(Power Factor:65%) Heater 344W Refrigeration 457W Defrost 344W
HEAT REJECTION	650W
POWER CORD	2.3m (Plug with Earth Wire)
EFFECTIVE CAPACITY	318L
OUTSIDE DIMENSIONS	1500mm(W)×600mm(D)×800(790-830)mm(H)
INSIDE DIMENSIONS	1140mm(W)×436mm(D)×599mm(H)
EXTERIOR	Precoated Steel, Galvanized Steel (Rear/Bottom) ABS Plastic (Front Panel)
INTERIOR	Precoated Steel, ABS Plastic (Door)
INSULATION	Polyurethane Foam
INSULATION FOAM	Cyclopentane
BLOWING AGENT	Forced Air Circulation
REFRIGERATION SYSTEM	Glass Tube Heater
DEFROST SYSTEM	Hermetic 410W (cooling capacity)
CONDENSER	Fin and Tube type, Air-cooled
EVAPORATOR	Fin and Tube Type
REFRIGERANT	R404A/160g
TEMPERATURE CONTROL	Microprocessor controlled Adjustable from -23 to -7℃
DEFROST CONTROL	Microprocessor controlled
ELECTRIC CIRCUIT PROTECTION	Fuse, Earth Wire
COMPRESSOR PROTECTION	Motor Protector
LEG	Plastic Adjustable 90 to 130mm
SHELF	4pcs. (include Bottom shelf)
WEIGHT	Net: 86kg (Gross: Approx. 91kg)
PACKAGE	Carton 1565mm(W)×680mm(D)×790mm(H)
ACCESSORIES	Drain Hose x 1(φ 26mm OD), Cable strap x 3
OPERATING CONDITIONS	Ambient Temperature:-38℃ Voltage Range:Rated Voltage±6%

- \* We reserve the right to make changes in specifications and design without prior notice.
1. Install the product properly in accordance with the instructions on location, electrical connections stated in the instruction manual provided.  
Allow 10mm extra space at the installation site to meet any installation requirements (additional spacing is also required for proper air flow and pipe connections).
  2. The heat rejection is based on the reached pull-down temperature at ambient temperature of 35℃ and power supply of 220V 50Hz.  
The amperage and electric consumption are based on measurements at ambient temperature of 38℃ and power supply of 220V 50Hz.
  3. The cabinet temperature range of -23 to -7℃ is guaranteed at ambient temperature of 30℃.
  4. Product code: T076

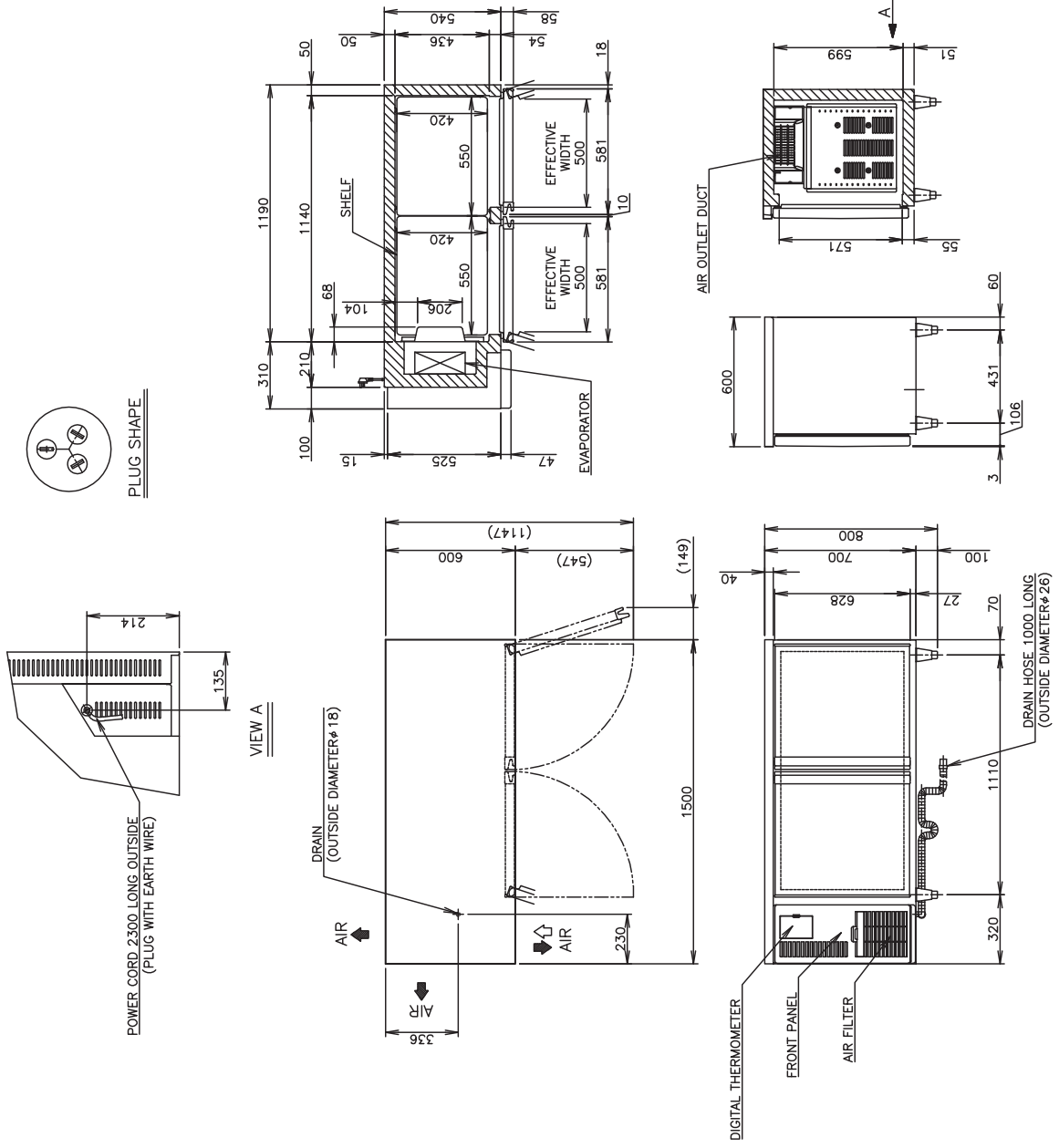

# FTC-150MDA

ITEM	Hoshizaki Undercounter Freezer
MODEL	FTC-150MDA
POWER SUPPLY	1 Phase 220-240V 50Hz Capacity:0.79kVA(3.6A)
AMPERAGE	Rated 2.2A
ELECTRIC CONSUMPTION	Motor 385W(Power Factor:83%) Heater 344W Refrigeration 427W Defrost 344W
HEAT REJECTION	704W
POWER CORD	2.3m (Plug with Earth Wire)
EFFECTIVE CAPACITY	420L
OUTSIDE DIMENSIONS	1500mm(W)×750mm(D)×800(790-830)mm(H)
INSIDE DIMENSIONS	1140mm(W)×568mm(D)×599mm(H)
EXTERIOR	Precoated Steel, Galvanized Steel (Rear/Bottom)
INTERIOR	ABS Plastic (Front Panel)
INSULATION	Precoated Steel, ABS Plastic (Door)
INSULATION FOAM	Polyurethane Foam
BLOWING AGENT	Cyclopentane
REFRIGERATION SYSTEM	Forced Air Circulation
DEFROST SYSTEM	Glass Tube Heater
COMPRESSOR	Hermetic 480W (cooling capacity)
CONDENSER	Fin and Tube type, Air-cooled
EVAPORATOR	Fin and Tube Type
REFRIGERANT	R404A/170g
TEMPERATURE CONTROL	Microprocessor controlled Adjustable from -23 to -7℃
DEFROST CONTROL	Microprocessor controlled
ELECTRIC CIRCUIT PROTECTION	Fuse, Earth Wire
COMPRESSOR PROTECTION	Motor Protector
LEG	Plastic Adjustable 90 to 130mm
SHELF	4pcs. (include Bottom shelf)
WEIGHT	Net: 93kg (Gross: Approx. 98kg)
PACKAGE	Carton 1565mm(W)×830mm(D)×790mm(H)
ACCESSORIES	Drain Hose x 1(φ 26mm OD), Cable strap x 3
OPERATING CONDITIONS	Ambient Temperature:5-38℃ Voltage:Rated Voltage±6%

■ We reserve the right to make changes in specifications and design without prior notice.

1. Install the product properly in accordance with the instructions on location, electrical connections stated in the instruction manual provided.  
Allow 10mm extra space at the installation site to meet any installation requirements (additional spacing is also required for proper air flow and pipe connections).
2. The heat rejection is based on the reached pull-down temperature at ambient temperature of 35℃ and power supply of 220V 50Hz.  
The amperage and electric consumption are based on measurements at ambient temperature of 38℃ and power supply of 220V 50Hz.
3. The cabinet temperature range of -23 to -7℃ is guaranteed at ambient temperature of 50℃.
4. Product code: T079

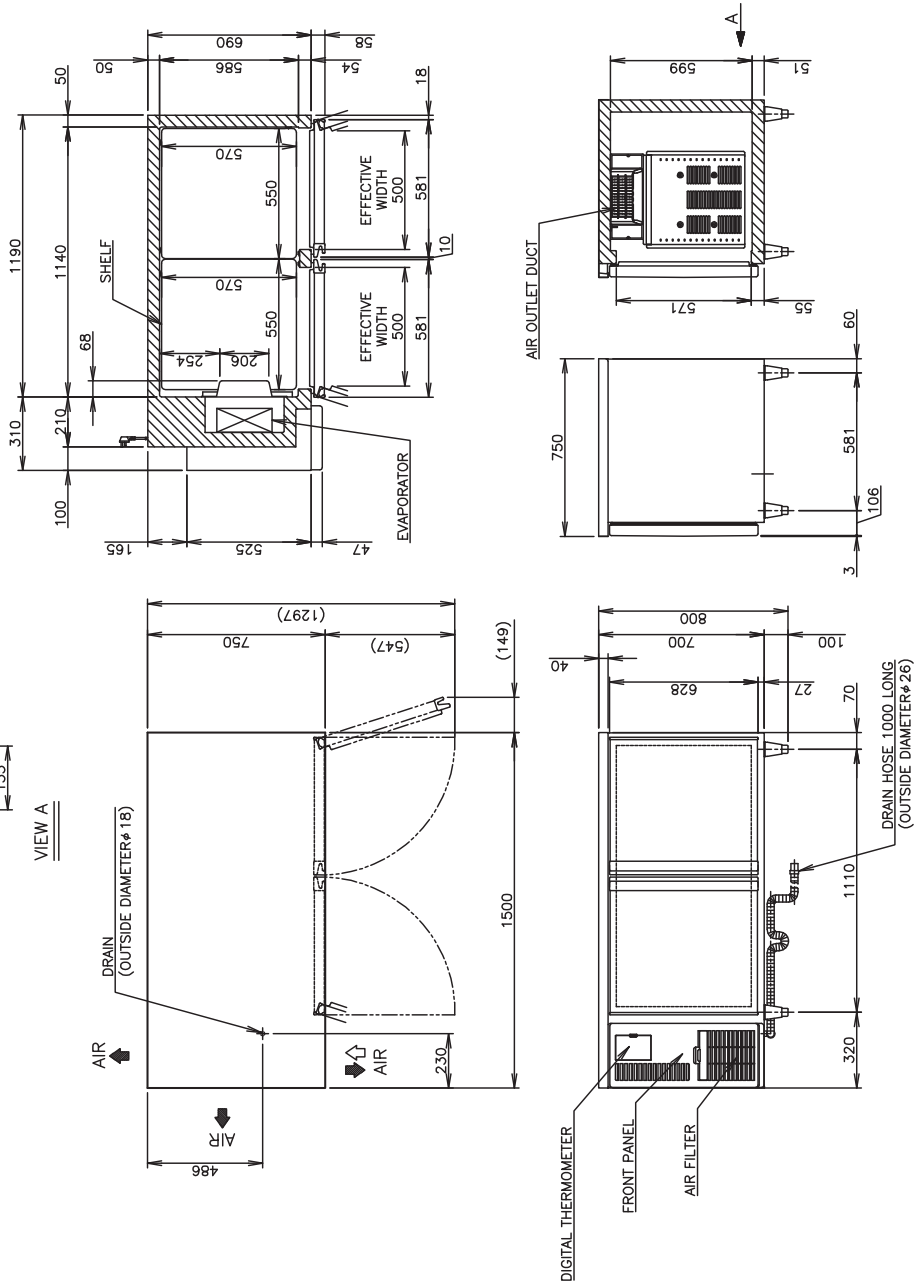
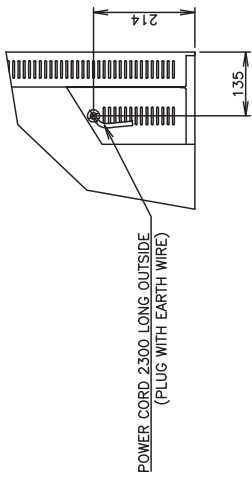
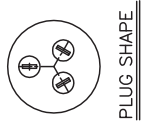

# [K] FTC-180MNA

ITEM	Hoshizaki Undercounter Freezer
MODEL	FTC-180MNA
POWER SUPPLY	1 Phase 220-240V 50Hz Capacity:0.79kVA(3.6A)
AMPERAGE	Rated 2.3A
ELECTRIC CONSUMPTION	Motor 400W(Power Factor86%) Heater 363W Refrigeration 461W Defrost 363W
HEAT REJECTION	704W
POWER CORD	2.3m (Plug with Earth Wire)
EFFECTIVE CAPACITY	401L
OUTSIDE DIMENSIONS	1800mm(W)×600mm(D)×800(790-830)mm(H)
INSIDE DIMENSIONS	1440mm(W)×436mm(D)×599mm(H)
EXTERIOR	Precoated Steel, Galvanized Steel (Rear/Bottom) ABS Plastic (Front Panel)
INTERIOR	Precoated Steel, ABS Plastic (Door)
INSULATION	Polyurethane Foam
INSULATION FOAM	Cyclopentane
BLOWING AGENT	Forced Air Circulation
REFRIGERATION SYSTEM	Glass Tube Heater
DEFROST SYSTEM	Hermetic 480W (cooling capacity)
COMPRESSOR	Fin and Tube type, Air-cooled
CONDENSER	Fin and Tube Type
EVAPORATOR	R404A/170g
REFRIGERANT	Microprocessor controlled Adjustable from -23 to -7℃
TEMPERATURE CONTROL	Microprocessor controlled
DEFROST CONTROL	Fuse, Earth Wire
ELECTRIC CIRCUIT PROTECTION	Motor Protector
COMPRESSOR PROTECTION	Plastic Adjustable 90 to 130mm
LEG	6pcs. (include Bottom shelf)
SHELF	Net: 99kg (Gross: Approx. 105kg)
WEIGHT	Carton 1865mm(W)×680mm(D)×790mm(H)
PACKAGE	Drain Hose x 1(φ26mm OD), Cable strap x 3
ACCESSORIES	Ambient Temperature:5-38℃ Voltage Range:Rated Voltage±6%
OPERATING CONDITIONS	

- \* We reserve the right to make changes in specifications and design without prior notice.
1. Install the product properly in accordance with the instructions on location, electrical connections stated in the instruction manual provided.  
Allow 10mm extra space at the installation site to meet any installation requirements(additional spacing is also required for proper air flow and pipe connections).
  2. The heat rejection is based on the reached shutdown temperature at ambient temperature of 35℃ and power supply of 220V 50Hz.  
The amperage and electric consumption are based on measurements at ambient temperature of 38℃ and power supply of 220V 50Hz.
  3. The cabinet temperature range of -23 to -7℃ is guaranteed at ambient temperature of 30℃.
  4. Product code: 1077



PLUG SHAPE

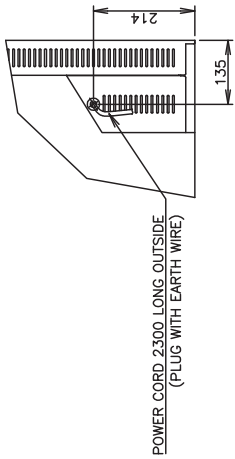

VIEW A(1/10)

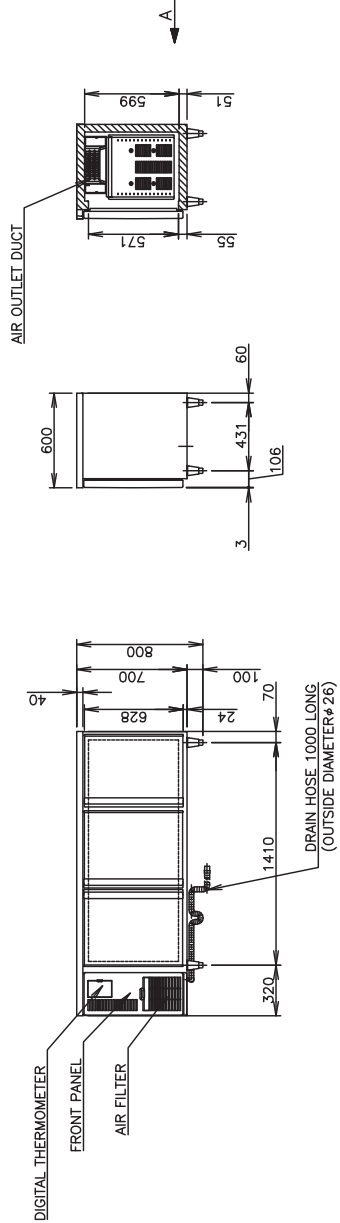
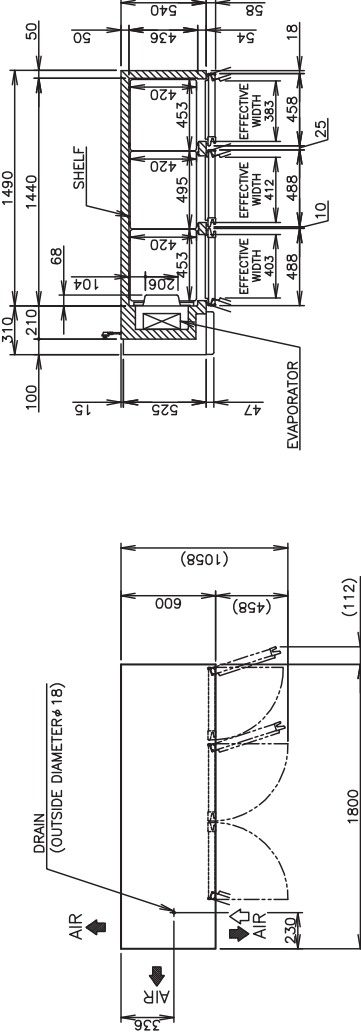



# [I] FTC-180MDA

ITEM	Hoshizaki Undercounter Freezer
MODEL	FTC-180MDA
POWER SUPPLY	1 Phase 220-240V 50Hz Capacity:0.7kVA(3.2A)
AMPERAGE	Rated 2.3A
ELECTRIC CONSUMPTION	Motor: 395W(Power Factor85%) Heater: 363W Refrigeration: 456W Defrost: 363W
HEAT REJECTION	690W
POWER CORD	2.3m (Plug with Earth Wire)
EFFECTIVE CAPACITY	502L
OUTSIDE DIMENSIONS	1800mm(W) x 750mm(D) x 800(790 - 830)mm(H)
INSIDE DIMENSIONS	1440mm(W) x 586mm(D) x 599mm(D)
EXTERIOR	Precoated Steel, Galvanized Steel (Rear, Bottom)
INTERIOR	Precoated Steel, ABS Plastic (Door)
INSULATION	Polyurethane Foam
INSULATION FOAM BLOWING AGENT	Cyclopentane
REFRIGERATION SYSTEM	Forced Air Circulation
DEFROST SYSTEM	Glass Tube Heater
COMPRESSOR	Hermetic 780W (cooling capacity)
CONDENSER	Fin and Tube type, Air-cooled
EVAPORATOR	Fin and Tube Type
REFRIGERANT	R404A/170g
TEMPERATURE CONTROL	Microprocessor controlled Adjustable from -23 to -7°C
DEFROST CONTROL	Microprocessor controlled
ELECTRIC CIRCUIT PROTECTION	Fuse, Earth Wire
COMPRESSOR PROTECTION	Motor Protector
LEG	Plastic Adjustable 90 to 130mm
SHELF	6pcs. (include Bottom shelf)
WEIGHT	Net: 107kg (Gross: Approx. 113kg)
PACKAGE	Carton 1865mm(W) x 830mm(D) x 790mm(H)
ACCESSORIES	Drain Hose x 1(φ26mm OD), Cable strap x 3
OPERATING CONDITIONS	Ambient Temperature: 5-43°C Voltage Range: Rated Voltage ±6%

\*We reserve the right to make changes in specifications and design without prior notice.

1. Install the product properly in accordance with the instructions on location, electrical connections stated in the instruction manual provided.  
Allow 10mm extra space at the installation site to meet any installation requirements (additional spacing is also required for proper air flow and pipe connections).
2. The heat rejection is based on the reached pull-down temperature at ambient temperature of 35°C and power supply of 220V 50Hz.  
The amperage and electric consumption are based on measurements at ambient temperature of 40°C and power supply of 220V 50Hz.
3. The cabinet temperature range of -23 to -7°C is guaranteed at ambient temperature of 30°C.
4. Product code: T080



PLUG SHAPE

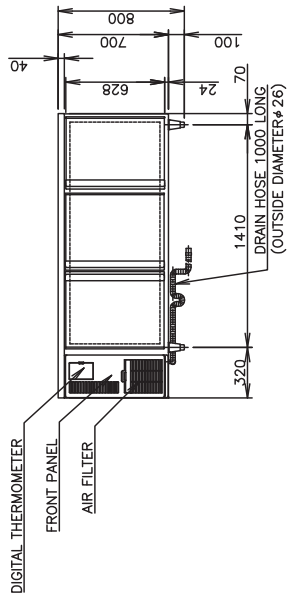
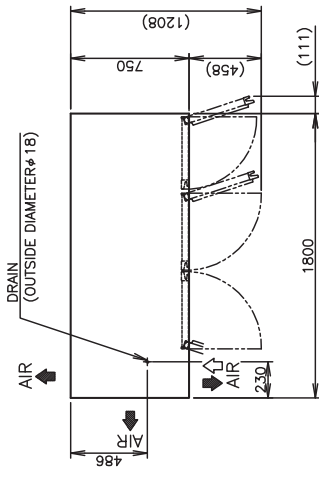
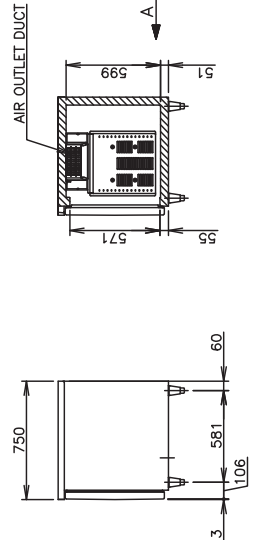
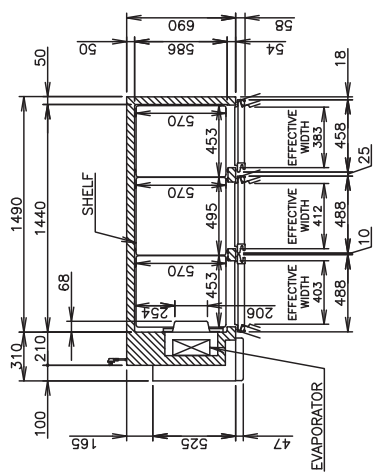
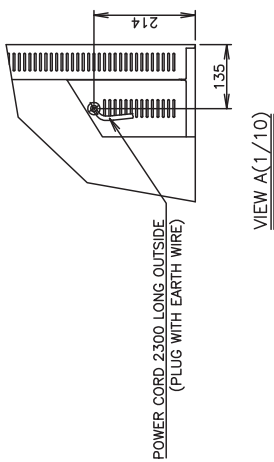

## II. TECHNICAL INFORMATION

### 1. WIRING DIAGRAM

#### [a] RTC SERIES

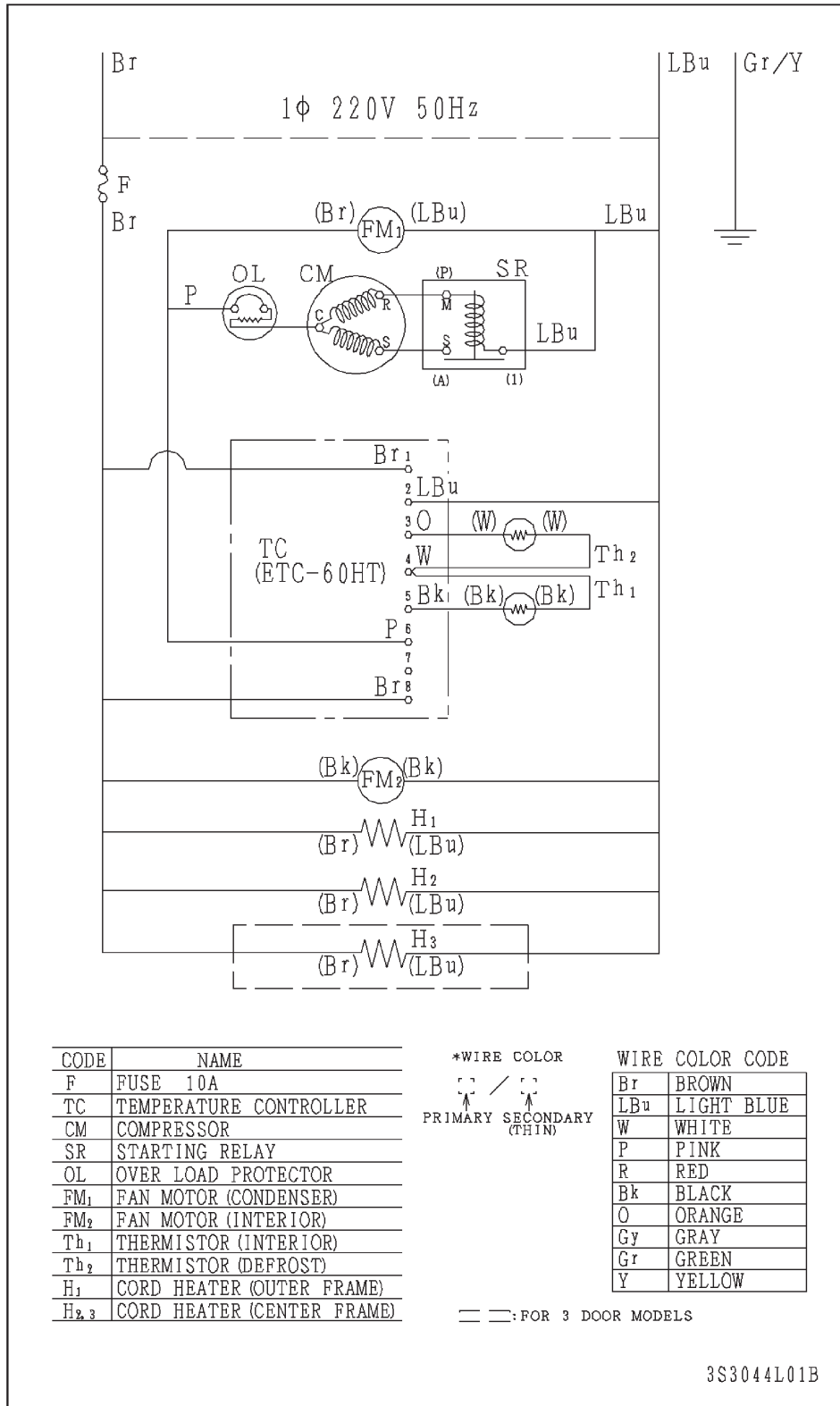

[b] FTC-120MNA, FTC-120MDA, FTC-150MNA

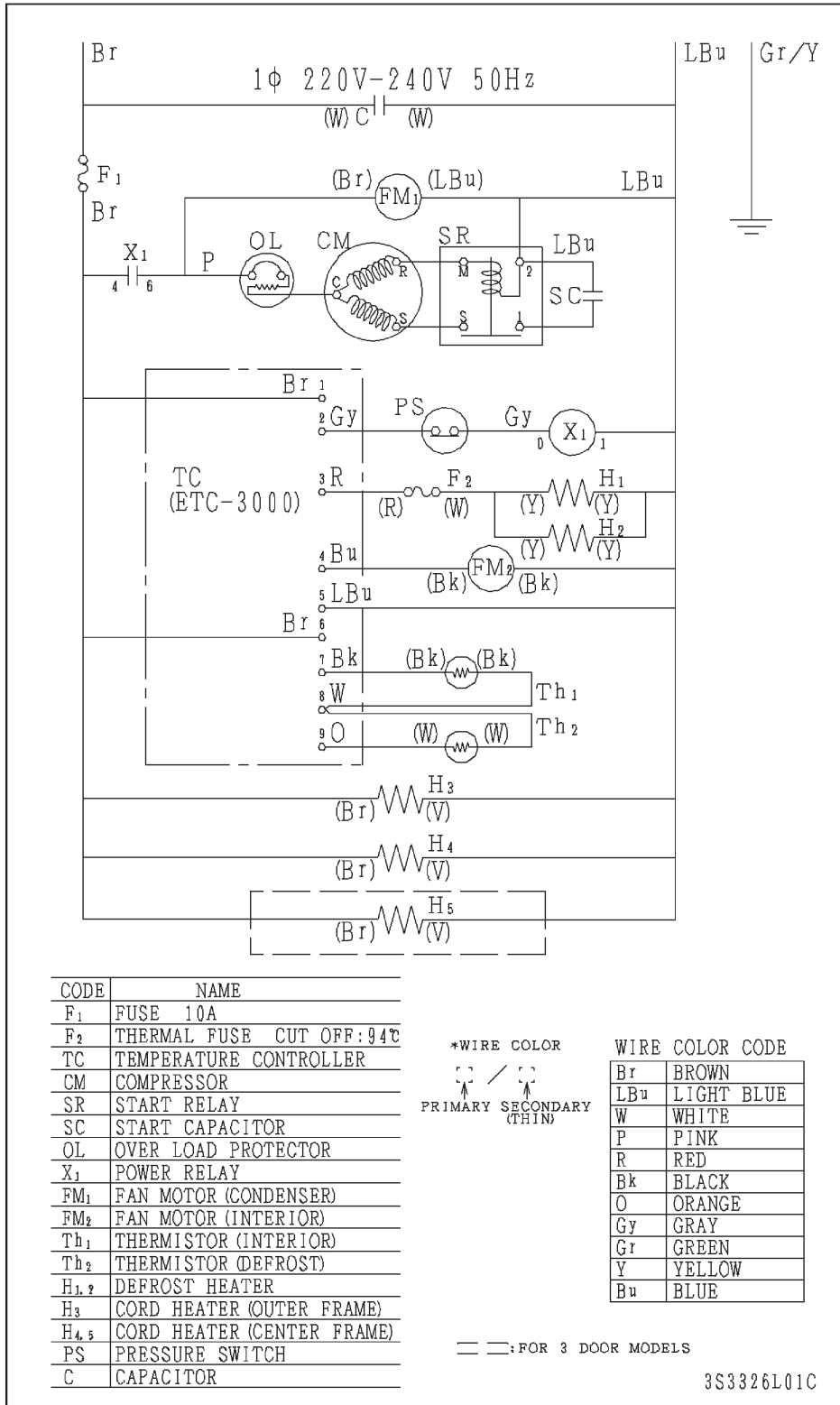

[c] FTC-150MDA, FTC-180MNA, FTC-180MDA

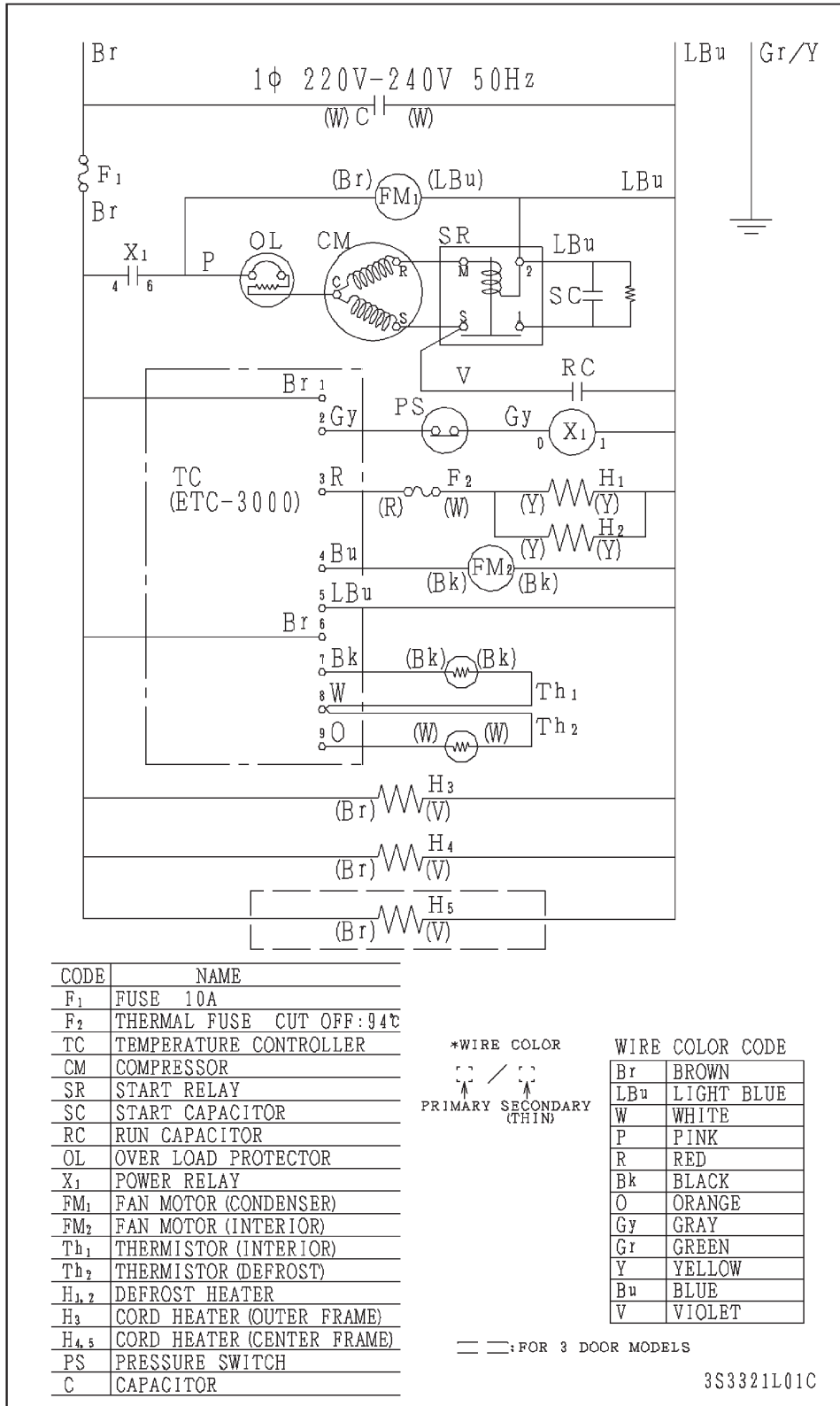

## 2. REFRIGERATION CIRCUIT

[a] RTC SERIES

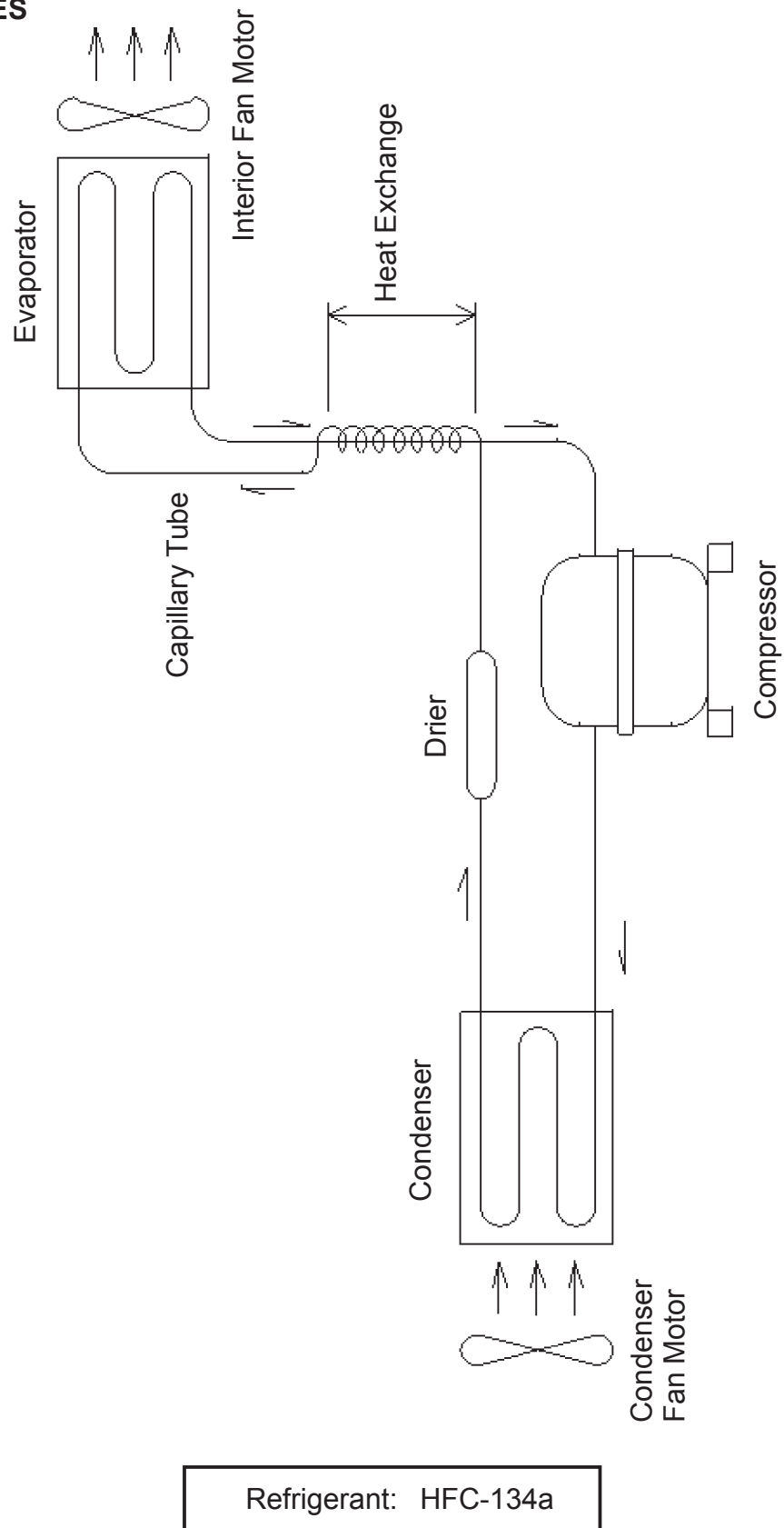

[b] FTC SERIES

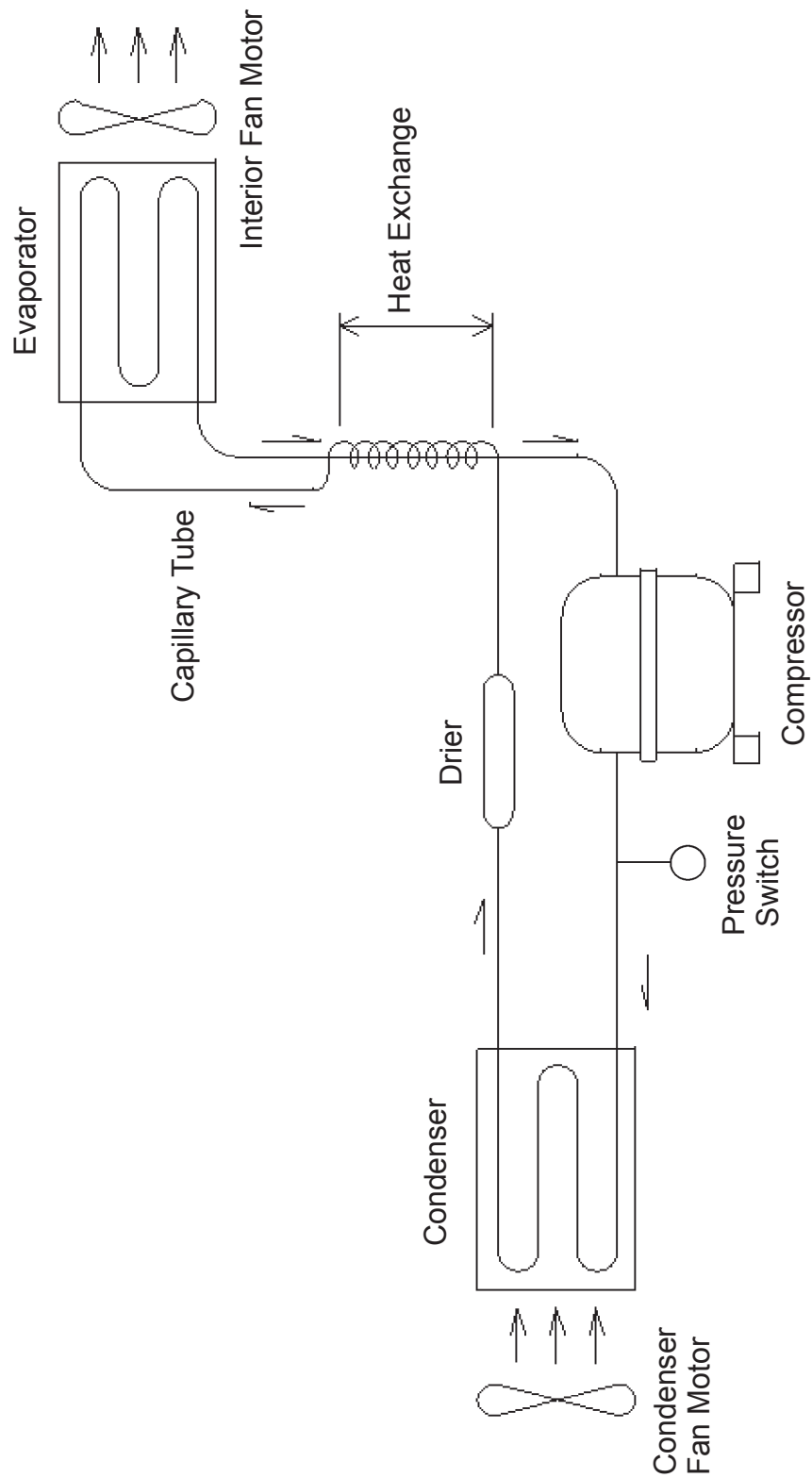

Refrigerant: HFC-404A

### 3. ELECTRONIC CONTROLS

#### [a] SET POINT TEMPERATURE (compressor OFF temperature)

Off-cycle defrost (RTC series): -2 to +12°C

Heater defrost (FTC series): -23 to -7°C

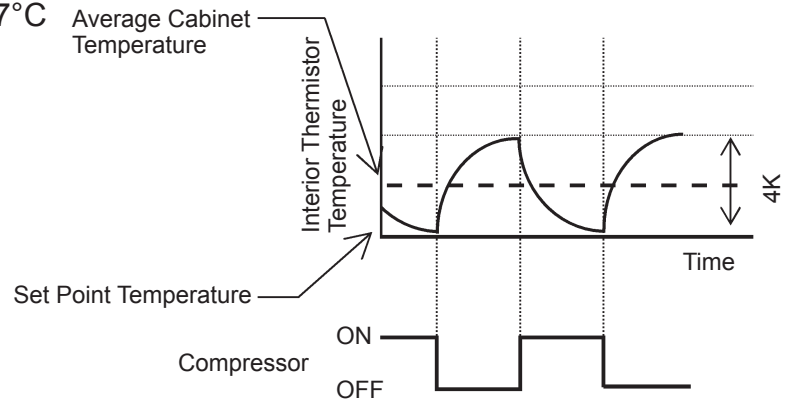

#### [b] CABINET TEMPERATURE DIFFERENTIAL

4 K (from “set point temp” to “set point temp + 4 K”)

The compressor stops when the cabinet temperature reaches down to the set point temperature, and starts when the cabinet temperature rises to the set point temperature + 4°C. Accordingly, the average cabinet temperature will be around the set point temperature + 2°C.

#### [c] DEFROST CYCLE

The unit automatically defrosts the evaporator 3 hours (RTC series) or 6 hours (FTC series) after the refrigeration starts. The defrost indicator light on the operation panel comes on when the defrost cycle starts.

#### [d] DEFROST TERMINATION TEMPERATURE

Off-cycle defrost (RTC series): +5°C

Heater defrost (FTC series): +20°C

#### [e] TEMPERATURE DISPLAY

During a defrost cycle, the screen indicates “dF” (FTC series only).

## [f] COMPRESSOR SOFT START

### 1) Startup

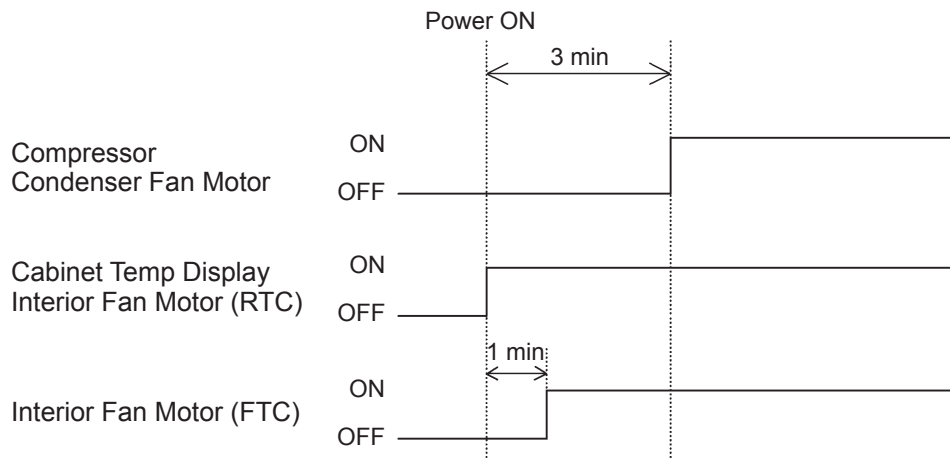

When the power supply is turned on, the screen shows the cabinet temperature and the interior fan motor starts up immediately (RTC series only) or with a 1 minute delay (FTC series). The compressor and condenser fan motor start up with a 3 minute delay. This delay is intended to minimize the difference between the high-side and low-side pressures and to reduce the load on the compressor so that it can start easily in case of a short (especially instantaneous) power failure.

### 2) Normal Control

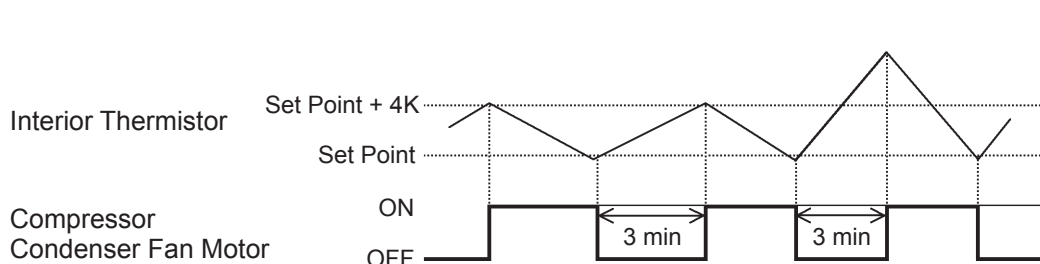

When the compressor turns off during normal control, it has a mandatory 3 minute delay before startup. For example, if the compressor turns off by its thermistor and the door is opened immediately after (causing the cabinet temperature to immediately exceed the restart temperature), the compressor will still not start until 3 minutes have passed since its shutdown.

### [g] HIGH PRESSURE SWITCH (FTC series only)

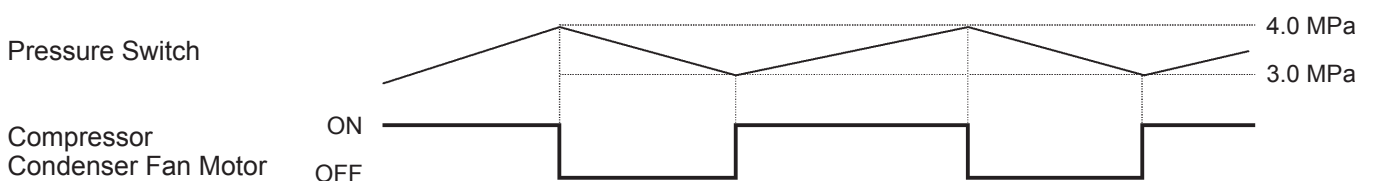



## [h] CHECKING SET POINT TEMPERATURE

Note: See “5. CONTROLLER” for the operation panel key locations.

### RTC series

Press and hold the up key on the operation panel to display the set point temperature on the screen. When releasing the up key, the screen displays the cabinet temperature again.

### FTC series

Press and hold the set key on the operation panel for 3 seconds to display “SEt” on the screen. Press the set key again to display the set point temperature on the screen. After 10 seconds, the screen displays the cabinet temperature again.

## [i] MANUAL DEFROST

To start the manual defrost cycle, press the defrost/rest key (RTC series) or defrost key (FTC series) for 3 seconds. The defrost indicator light on the operation panel comes on when the defrost cycle starts.

## [j] ERROR CODES

### RTC series

Code	Possible Cause	Operation and Remedy
E1	Cabinet sensor (interior thermistor) error	Compressor shuts down. Press any key to stop beep. When troubleshooting is over, system recalculates compressor delay time. See “III. 1. ERROR CODES” for further details.
E2	Evaporator (defrost thermistor) error	Defrost termination temperature is invalid. Press any key to stop beep. See “III. 1. ERROR CODES” for further details.

### FTC series

Code	Possible Cause	Operation and Remedy
HHH	Cabinet sensor (interior thermistor) error	Compressor cycles on for 45 minutes and off for 15 minutes. Check cabinet temperature. See “III. 1. ERROR CODES” for further details.
LLL		
HHH * With [6] down key pressed	Cabinet sensor (defrost thermistor) error	Forcibly finishes defrost cycle at the end of defrost time. See “III. 1. ERROR CODES” for further details.
LLL * With [6] down key pressed		

\* The code “dF” is not an error code but indicates the unit is in defrost cycle.

\* When the defrost thermistor is defective, error code will not be displayed without [6] down key being pressed. See “II. 5. [b] FTC SERIES” for operation panel detail.

# 4. TIMING CHART

## [a] STARTUP - CONTROL

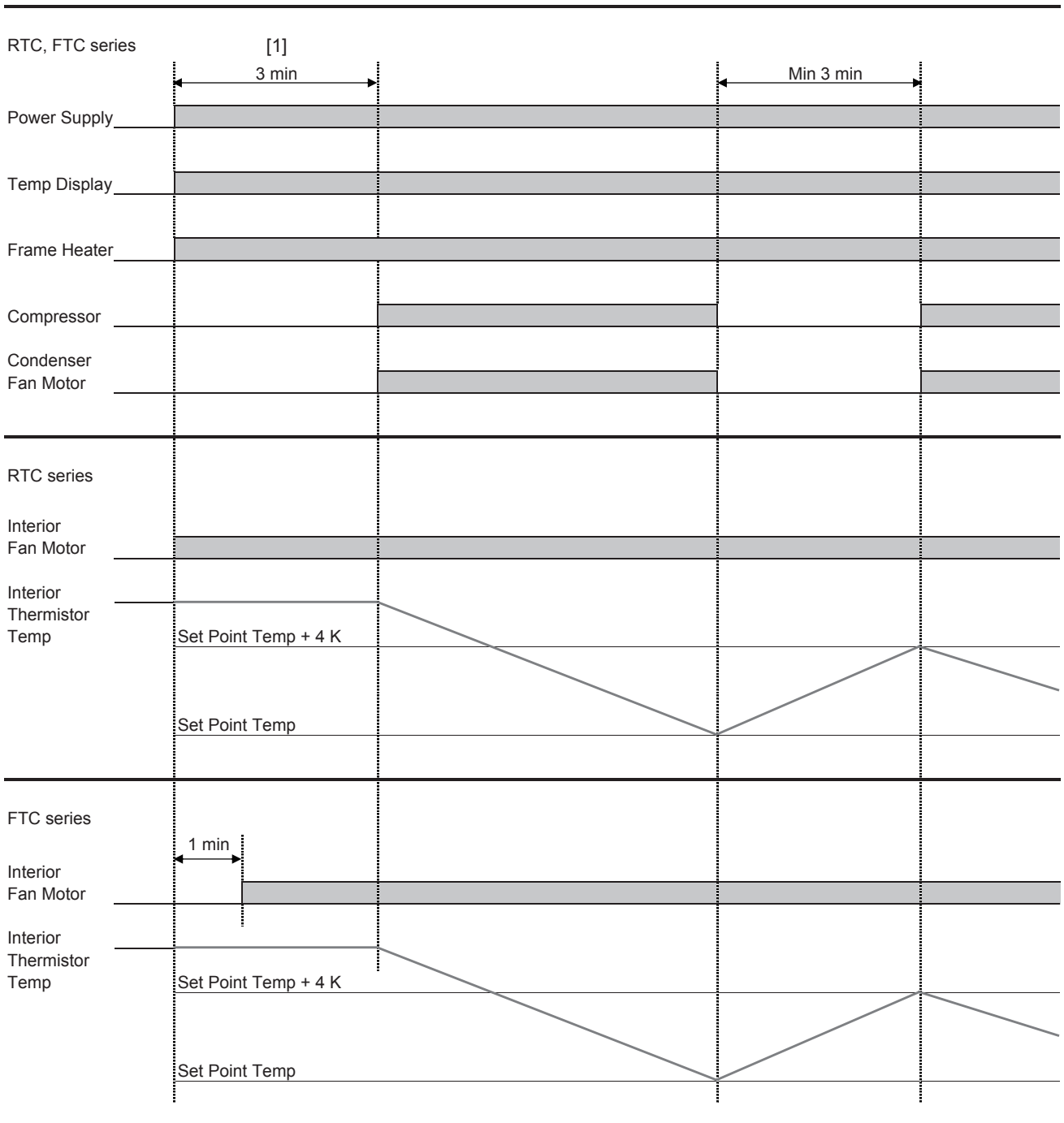

[1] Standby at Startup

Only temperature indication is available for 3 min (not a sign of failure).

## [b] DEFROST

RTC series (Off-cycle defrost)

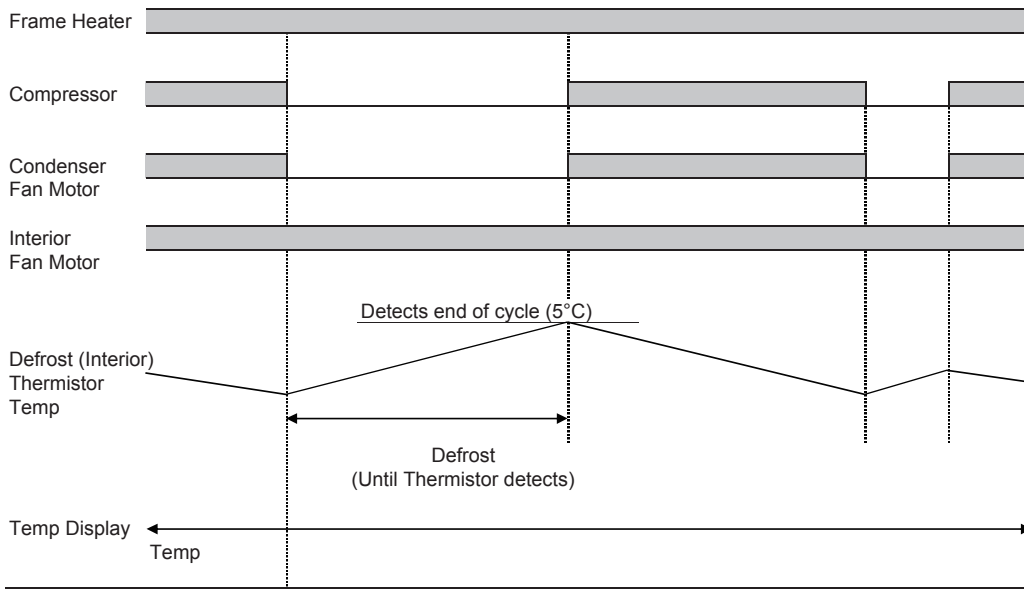

FTC series (Heater defrost)

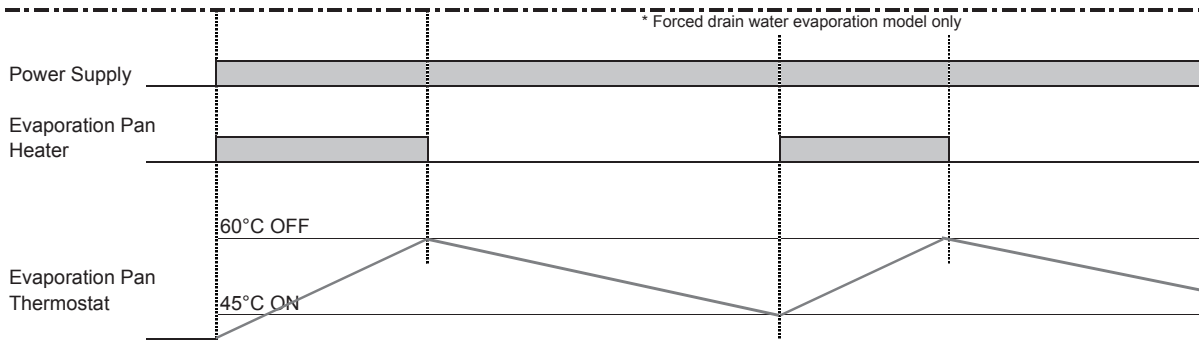
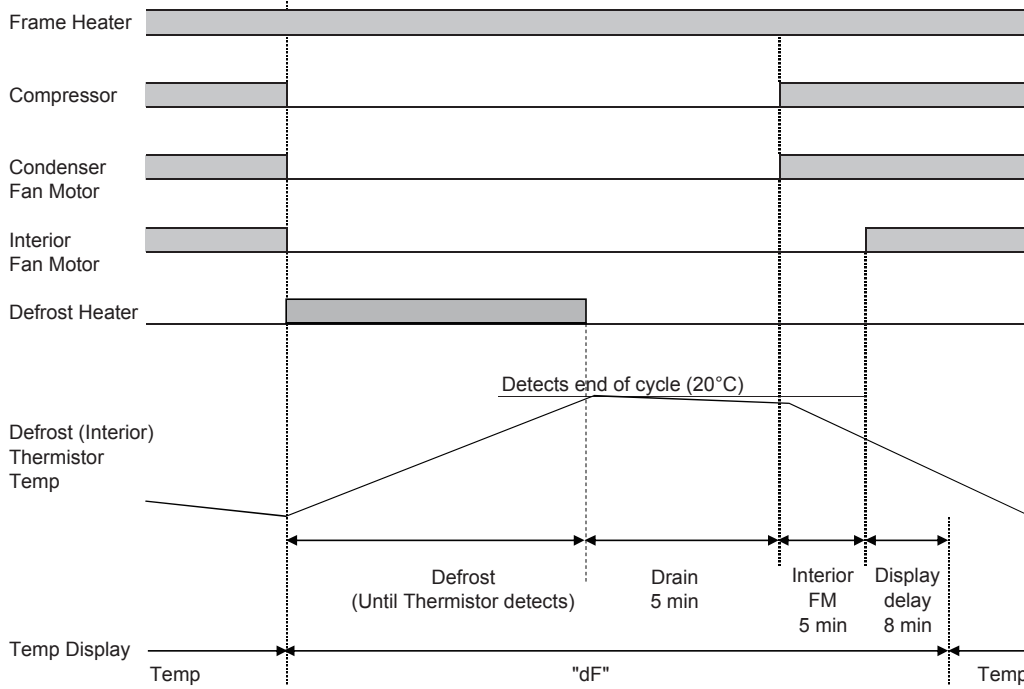

## 5. CONTROLLER

### [a] RTC SERIES

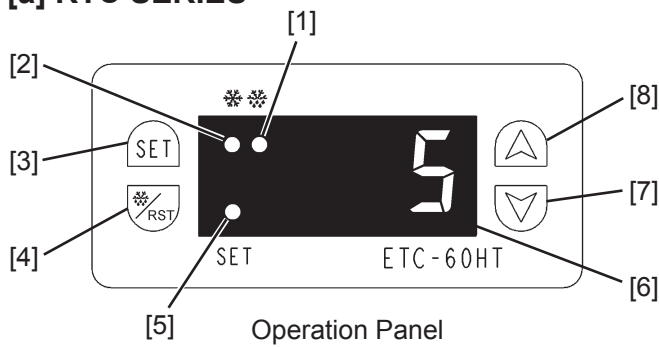

- [1] Defrost Indicator Light
- [2] Refrigeration Indicator Light
- [3] Set Key
- [4] Defrost/Reset Key
- [5] Set Indicator Light
- [6] Screen
- [7] Down Key
- [8] Up Key

### Indicator Lights

Indicator Light	Symbol	Status	Meaning
Set indicator light	SET	On	Parameter setting
		Off	Measuring and controlling status
		Flash	Parameter check, password input
Refrigeration indicator light	❄️	On	Refrigerating
		Off	Refrigeration stopped
		Flash	Refrigeration delayed
Defrost indicator light	❄️	On	Defrosting
		Off	Defrost stopped

### Parameters

Code	Function	Set Range	Default	Unit
F01	Menu password	00 to 99 00: cancel keypad lock function	55	NC
F02	Temperature value setting	-2 to +12	1	°C
F03	Temperature return difference setting	1 to 15	4	°C
F04	Delay time of compressor startup	1 to 15	3	min
F05	Cabinet temperature calibration	-5 to +5	-1	°C
F06	Maximum defrost time	1 to 60	60	min
F07	Defrost cycle	1 to 30	6	30 min
F08	Defrost termination temperature	-20 to +30	5	°C
F09	Whether activate evaporator sensor or not	00: inactivate 01: activate	1	NC

### Key Functions

Key	Function
Set key SET	Press to enter password input status; Parameter setting mode; Switch mode between menu and parameter
Up key ▲	Press to check set point temperature; Choose menu item; Adjust parameter and password value
Down key ▼	Press to check evaporator sensor value; Choose menu item; Adjust parameter and password value
Defrost/reset key ❄️/RST	Exit parameter setting status; Manually start or stop defrosting

## Operations

### 1. Under temperature measuring and controlling status:

#### 1) Press the set key for 3 seconds:

When the keypad password is set as "0", the set indicator light comes on and the screen displays the "F01" menu. There is no password authentication, so directly enter the menu mode to set parameter.

When the keypad password is not set as "0", the set indicator light flashes and the screen displays "00". Press the up or down key to input the password. Press the set key to confirm the password input. Then, the system enters the menu setting status if the password is correct. If the password is incorrect, the set indicator light goes off and the system goes back to the normal measuring and controlling status.

#### 2) Parameter check:

Press the up key. The set indicator light flashes and the screen displays the set point temperature.

Press the down key. The set indicator light flashes and the screen displays the temperature of the evaporator sensor.

### 2. After entering the menu setting status, press the up or down key to choose the desired menu item (from F01 to F09).

### 3. After choosing the desired menu item, press the set key to set parameter value. Press the up or down key to adjust parameter value, and then repress the set key to go back to the menu setting status.

### 4. Under the setting status, press the defrost/reset key or perform no operation for 30 seconds. The system will save the parameters and exit from the parameter setting mode.

### 5. Press the defrost/reset key for 3 seconds to start or stop the manual defrost cycle.

## Output Control

### 1. Compressor:

The compressor starts up when the delay time runs out, if the measured temperature is higher than the "fixed temperature value + temperature return difference".

The compressor stops running when the measured temperature is lower than the set point temperature.

### 2. Defrosting:

Defrosting starts automatically according to the defrost cycle setting, or can be started manually. If the evaporator sensor is activated and the evaporator sensor temperature is higher than the defrost termination temperature, the manual start is not available.

Defrosting stops automatically when the evaporator temperature reaches the defrost termination temperature or when the defrost time runs out, or can be stopped manually. If the evaporator sensor is not activated or in error, defrosting stops when the defrost time runs out, or can be stopped manually.

### Sensor Error Alarm

Alarm Code	Possible Cause	Operation
E1	Cabinet sensor (interior thermistor) error	Compressor shuts down. When troubleshooting is over, system recalculates compressor delay time.
E2	Evaporator sensor (defrost thermistor) error	Defrost termination temperature is invalid.

### Wiring Diagram

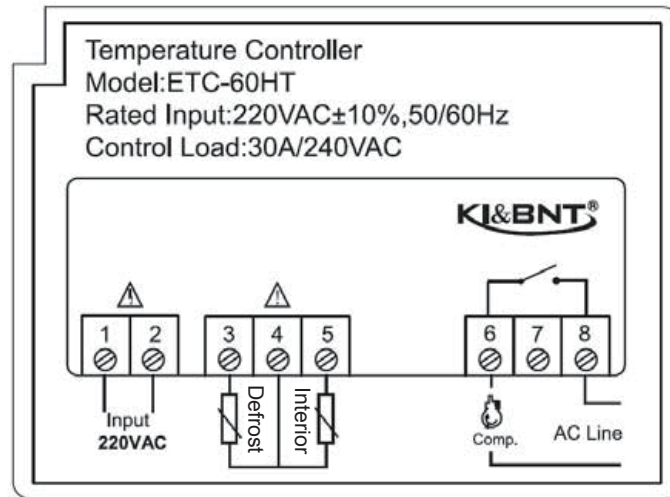

## [b] FTC SERIES

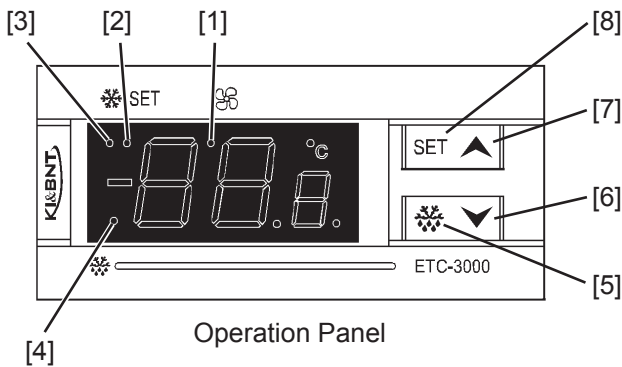

- [1] Fan Indicator Light
- [2] Set Indicator Light
- [3] Refrigeration Indicator Light
- [4] Defrost Indicator Light
- [5] Defrost Key
- [6] Down Key
- [7] Up Key
- [8] Set Key

### Indicator Lights

Indicator Light	Symbol	Status	Meaning
Refrigeration	❄️	On	Compressor running
		Off	Compressor stopped
		Flash	Compressor delayed
		Quick flash	Manual refrigeration
Defrost	❄️	On	Defrosting
		Off	Defrost stopped
		Flash	Defrost drain
		Quick flash	Manual defrost
Fan	🌀	On	Fan running
		Off	Fan stopped
		Flash	Fan delayed
Set	SET	On	Setting mode
		Off	Normal mode
Celsius	C	On	Celsius display under normal mode
		Off	Fahrenheit display under normal mode

### Key Functions and Setting Modes

Key Operation	Function 1 (Normal Mode)	Function 2 (User Setting Mode)	Function 3 (Administrator Setting Mode)
Set		Enter parameter setting	Save parameter and return to setting interface
Set (3 sec)	Enter user setting	Exit setting	Exit setting
Set + Down (10 sec)	Enter administrator setting		
Down		Check menu item	Calibrate parameter
Down (3 sec)		Fast forward menu item	Quickly calibrate parameter
Up	Upload copy key	Check menu item	Calibrate parameter
Up (3 sec) *See Note	Start/stop forced refrigeration	Fast rewind menu item	Quickly calibrate parameter
Defrost (3 sec)	Start/stop manual defrost		
Up + Down (10 sec)	Lock key operation		

Note: Do not use "Up (3 sec)" in normal mode because defrost cycle may not start.

If "Up (3 sec)" key operation starts forced refrigeration, defrost cycle will not start until temperature reaches set point. During forced refrigeration, [3] refrigeration indication light will flash quickly. Forced refrigeration can be cancelled by "Up (3 sec)" key operation. After cancellation, defrost cycle will automatically start.

## Parameters

Menu	Item	Range	Default	Remark
User	SEt	Min temp setting to max temp setting	-20	Temp parameter setting
Administrator	HY	1 to 25°C	4	Return difference setting
	MdF	0 to 255 min	60	Defrost time
	ldF	0 to 120 hrs	6	Defrost cycle
	LS	-45.5°C to SEt	-23	Min temp setting
	US	SEt to 99.9°C	-7	Max temp setting
	ot	-10 to +10°C	0.5	Room temp calibration
	oE	-10 to +10°C	0	Defrost temp calibration
	AC	0 to 50 min	4	Compressor delay time
	CON	0 to 255 min	45	Interior thermistor error compressor ON time
	CoF	0 to 255 min	15	Interior thermistor error compressor OFF time
	CF	°C: Celsius °F: Fahrenheit	°C	Temp measurement unit
	tdF	EL: 0 (Electric heating) HtG: 1 (Thermal)	EL	Defrost type
	dtF	-45.5 to +49.9°C	20	Defrost termination temp
	dFd	Rt: 0 (Normal display of room temp) lt: 1 (Defrost start temp) SEt: 2 (Display set point) dEF: 3 (Display dF)	dEF	Display delay after defrosting
	dAd	0 to 255 min	18	Display delay time after defrosting
	Fdt	0 to 255 min	5	Draining time after defrost
	dPo	y: 0 (Immediately) n: 1 (Later)	n	Defrost cycle at initial startup
	dAF	0 to 24 hrs	0	Defrost delay after forced refrigeration
	FnC	C-N: Start/stop with compressor, OFF when defrosting O-N: Continuous, OFF when defrosting C-Y: Start/stop with compressor, ON when defrosting O-Y: Continuous, ON when defrosting	O-N	Fan operation mode
	Fnd	0 to 255 min	10	Fan delay after defrosting
	FCt	0 to 50°C	50	Forced startup by difference between room temp and evaporator temp
	ALU	ALL to 99.9°C	110	Upper alarm temp limit
	ALL	-45.5°C to ALU	-45.5	Lower alarm temp limit
ALd	0 to 255 min	15	Temp alarm delay	
dAo	0 to 24	1	Temp alarm delay after energized	
Cot	0 to 255 min	0	Thermistor error delay	
FSt	-45.5 to 49.9	40	Fan stop temp	



## Operations

### 1. Compressor functions:

#### A. Under electric heating defrost mode:

Start condition: Compressor relay closes when both a) and b) or both a) and c) are met.

- a) Compressor delay time exceeds the set delay time.
- b) Forced refrigeration starts when the room temperature is higher than the set point temperature.
- c) Under non-defrost mode, the room temperature is higher than the set point temperature + return difference.

Stop condition: Compressor relay opens when any of the following conditions is met.

- a) Room temperature is lower than the set point temperature.
- b) At the start of defrost cycle.
- c) Forced refrigeration stops.

#### B. Under thermal defrost mode:

Start condition: Compressor relay closes when both a) and b), both a) and c) or both a) and d) are met.

- a) Compressor delay time exceeds the set delay time.
- b) Under non-defrost mode, the room temperature is higher than the set point temperature + return difference.
- c) Forced refrigeration starts when the room temperature is higher than the set point temperature.
- d) In defrost cycle.

Stop condition: Compressor relay opens when any of the following conditions is met.

- a) Room temperature is lower than the set point temperature.
- b) At the end of defrost cycle.
- c) Forced refrigeration stops, and defrost cycle does not start immediately.

### 2. Defrost functions:

Defrost relay closes when the following conditions are met.

- a) Defrost delay time meets the set delay time.
- b) Defrost thermistor temperature is lower than the defrost termination temperature.
- c) Defrost cycle ends or manual defrost starts.

Defrost relay opens when any of the following conditions is met.

- a) Defrost time runs out.
- b) Defrost thermistor temperature is higher than the defrost termination temperature.

### 3. Fan functions:

Fan relay closes when any of the following conditions is met.

- a) Defrost temperature is higher than the fan stop temperature; Difference between room temperature and evaporator temperature is more than the set difference.
- b) Operation mode “0”; Compressor starts; Defrost thermistor temperature is lower than the fan stop temperature; Fan delay time after defrost exceeds the set value.
- c) Operation mode “1”; Under non-defrost mode, the defrost temperature is lower than the fan stop temperature; Fan delay time after defrost exceeds the set value.
- d) Operation mode “2”; When the compressor is running or during defrost cycle, the defrost temperature is lower than the fan stop temperature; Fan delay time after defrost exceeds the set value.
- e) Operation mode “3”; Defrost temperature is lower than the fan stop temperature.

Fan relay opens when the following conditions are met.

- a) Defrost temperature is higher than the fan stop temperature; Difference between room temperature and evaporator temperature is less than the set difference.
- b) Operation mode “0”; Compressor stops or defrost starts.
- c) Operation mode “1”; Defrost starts.
- d) Operation mode “2”; Compressor stops.

### 4. Alarm functions:

LED flashes and displays alarm information when the room temperature exceeds the upper or lower alarm temperature limit and the set alarm delay time runs out.

LED displays “HHH” when the room temperature exceeds the upper limit of measured temperature or the thermistor short-circuits and runs out of the thermistor error delay time.

LED displays “LLL” when the room temperature is lower than the lower limit of measured temperature or the thermistor short-circuits and runs out of the thermistor error delay time.

### 5. Copy key operations:

Under the controller power-on mode, plug in the copy key and press the up key to display “UPL”. At this time, press the set key to upload the parameters to the copy key. LED displays normal temperature after uploading. Then, turn off the controller and unplug the copy key. LED flashes and displays “err” if there is any error while uploading.

Under the controller power-off mode, plug in the copy key and turn on the controller. At this time, the controller automatically detects the copy key and downloads the parameters. LED displays “DOW” while downloading and “End” after downloading. Then, turn off the controller and unplug the copy key. Restart the controller. LED flashes and displays “err” if there is any parameter error or controller model error.

### 6. Key lock functions:

Under normal mode, press and hold the up and down keys at the same time for 10 seconds to turn on/off the key lock. At this time, LED displays the key lock on/off mode. Release the up and down keys. LED displays normal temperature. All the parameters can be checked but cannot be modified.

# Wiring Diagram

ETC-3000

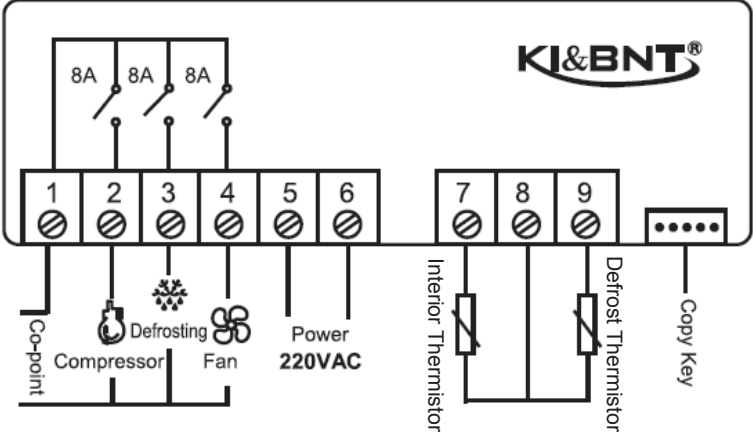

### III. SERVICE DIAGNOSIS

#### 1. ERROR CODES

##### [a] RTC SERIES

Code	Display	Error	Description	Possible Cause	Reset
E1	E1 only	Interior thermistor defective	Interior thermistor is defective. Compressor stops. Beeper sounds.	<ul style="list-style-type: none"> <li>Interior thermistor circuit open, connector unplugged</li> <li>Interior thermistor circuit shorted, dusty connector</li> </ul>	<ul style="list-style-type: none"> <li>Press any key to stop beep</li> <li>Automatically resets after cause is removed</li> </ul>
E2	E2 and temperature alternately	Defrost thermistor defective	Defrost thermistor is defective. Defrost cycle ends by timer control. Beeper sounds.	<ul style="list-style-type: none"> <li>Defrost Thermistor circuit open, connector unplugged</li> <li>Defrost Thermistor circuit shorted, dusty connector</li> </ul>	<ul style="list-style-type: none"> <li>Press any key to stop beep</li> <li>Automatically resets after cause is removed</li> </ul>

##### [b] FTC SERIES

Display	Error	Description	Possible Cause	Reset
HHH	Interior thermistor defective	Repeats starting and stopping operation at certain interval.	Interior thermistor circuit shorted, dusty connector	Automatically resets after cause is removed
LLL		Repeats starting and stopping operation at certain interval.	Interior thermistor circuit open, connector unplugged	Automatically resets after cause is removed
HHH * With [6] down key pressed	Defrost thermistor defective	Forcibly finishes defrost cycle at the end of defrost time and starts normal operation.	Defrost Thermistor circuit shorted, dusty terminal	Automatically resets after cause is removed
LLL * With [6] down key pressed		Forcibly finishes defrost cycle at the end of defrost time and starts normal operation.	Defrost Thermistor circuit open, connector unplugged	Automatically resets after cause is removed

\* When the defrost thermistor is defective, error code will not be displayed without [6] down key being pressed. See "II. 5. [b] FTC SERIES" for operation panel detail.

# 2. FLOWCHART

## [a] RTC SERIES

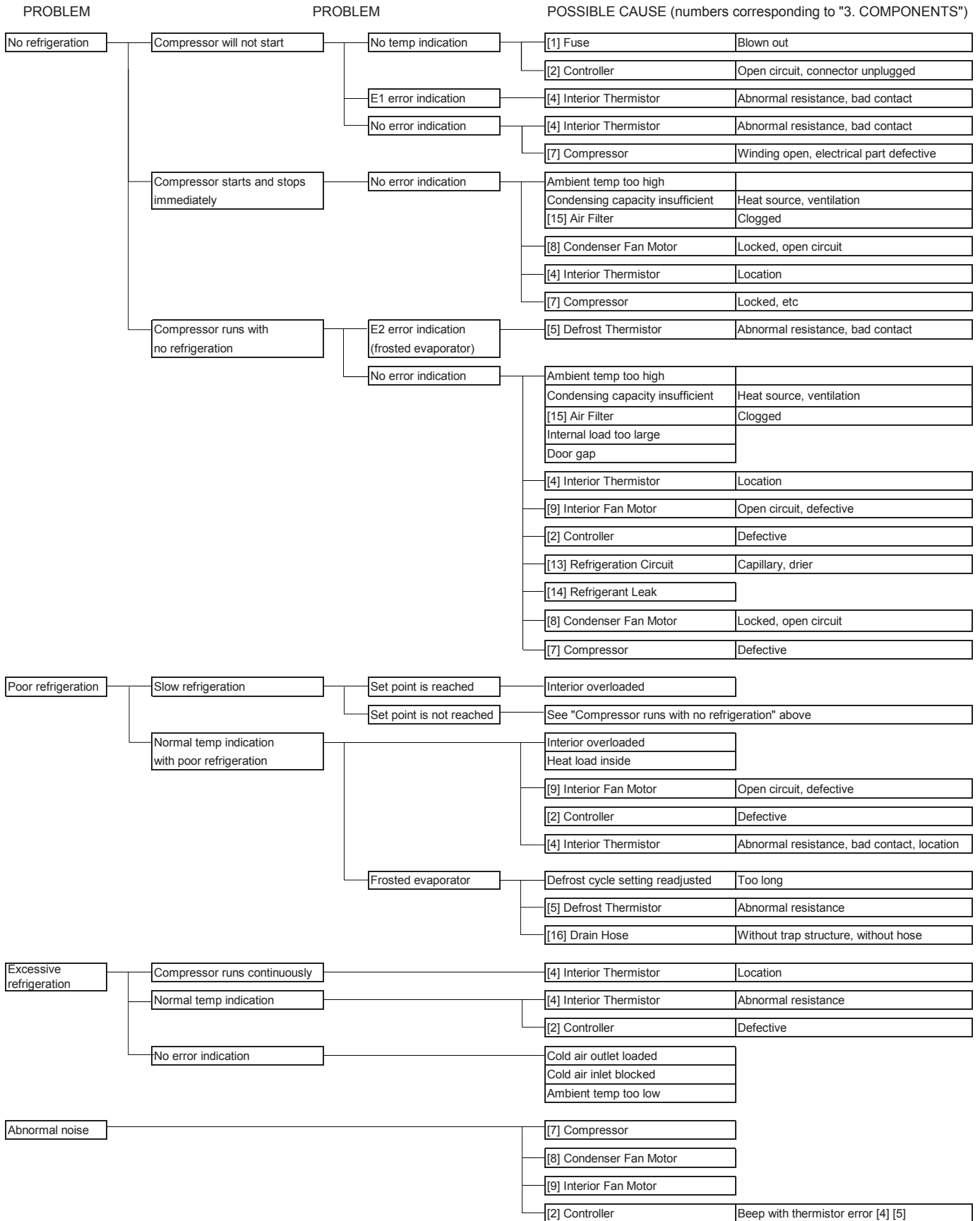

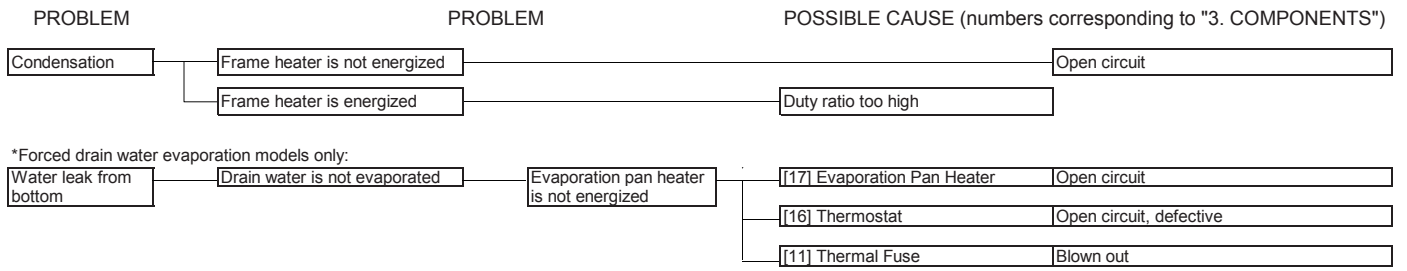

# [b] FTC SERIES

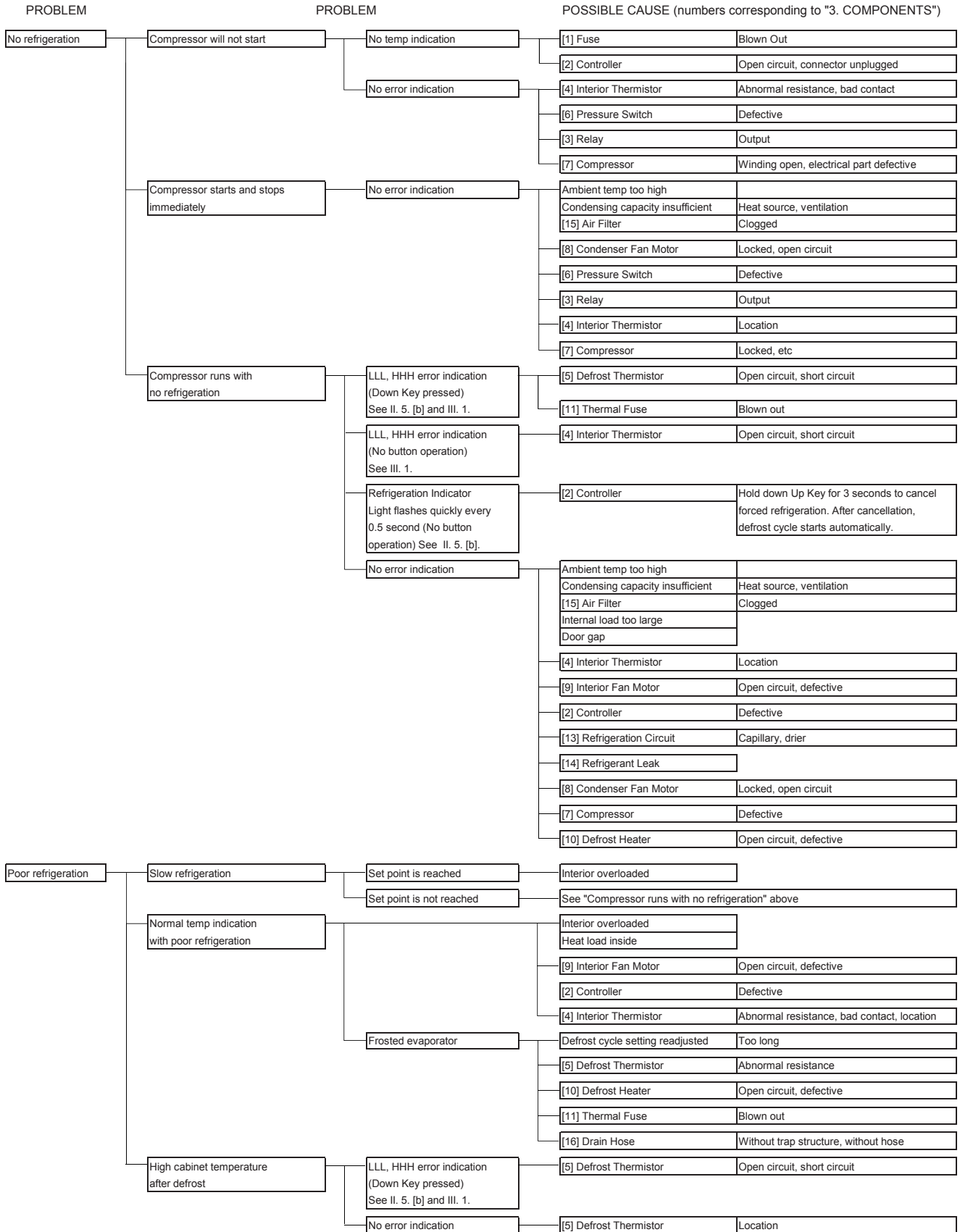

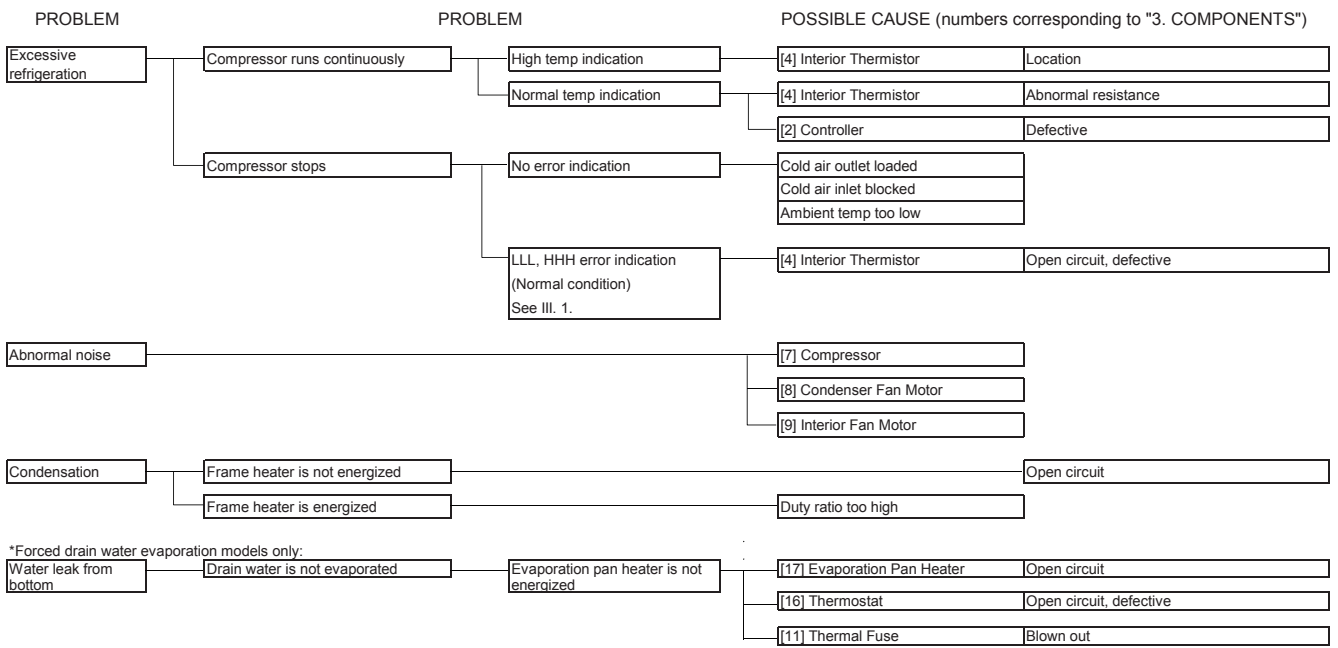



### 3. COMPONENTS

CHART NO.	COMPONENT	CHECK	REMEDY	
[1]	Fuse	Blown out	Replace	
[2]	Controller	Open circuit	Correct or replace	
		Input/output (interior fan motor) See wiring label	Replace	
		Connector disconnected	Correct	
		Connector dusty/dirty	Remove	
		7 segment display partially/totally off	Replace	
		Electronic parts defective/burnt out		
[3]	Relay	Fast-on terminal/pin disconnected	Correct	
		Connector dusty/dirty	Remove	
		Open circuit	Correct	
		Output to each load Check with wiring diagram/timing chart	Replace	
		Abnormal noise		
[4]	Interior Thermistor	Location (holder in front of evaporator) Disconnected, replaced with defrost thermistor, etc	Correct	
		Incorrect temp indication	Immerse in ice water to check resistance (25 - 30k) Replace if necessary	
		(RTC series)	Short circuit (temp displayed as "E1")	Clean/dry connector Replace
			Open circuit (temp displayed as "E1")	Replace
		(FTC series)	Short circuit (temp displayed as "HHH")	Clean/dry connector Replace
			Open circuit (temp displayed as "LLL")	Replace
[5]	Defrost Thermistor	Location (plug in from evaporator back) Disconnected, replaced with interior thermistor, etc	Correct	
		Abnormal resistance	Immerse in ice water to check resistance (25 - 30k) Replace if necessary	
		(RTC series)	Short circuit (temp displayed as "E2")	Clean/dry connector Replace
			Open circuit (temp displayed as "E2")	Replace
		(FTC series)	Short circuit (temp displayed as "HHH")	Clean/dry connector Replace
			Open circuit (temp displayed as "LLL")	Replace
[6]	Pressure Switch	Open circuit	Replace	
[7]	Compressor	Resistance between terminals (at 25°C)	Replace	
		Compressor	Winding resistance (Ω)	
			Start	Run
		AZ0411Y	26.85	11.10
		AE2416ZK	24.27	5.71
		AE2420ZK-SR	17.70	6.10
		AE2432ZK	8.56	3.26
		Abnormal noise		
		Insufficient compression (discharge temp too low)		Replace if no gas leaks
		Compressor electrical part defective - Run/start capacitor ruptured/deformed - Capacitor defective Check resistance between terminals Gradually reduces: No problem 0 from start: Defective - Starter defective Loose terminal, no conductivity, damaged - Overload relay defective Loose terminal, no conductivity, damaged		Replace
[8]	Condenser Fan Motor	Open circuit	Correct	
		Locked (not rotating with voltage)	Replace	
		Abnormal noise		
		Burning smell		
[9]	Interior Fan Motor	Open circuit	Correct	
		Locked (not rotating with voltage)	Replace	
		Abnormal noise		
		Burning smell		

CHART NO.	COMPONENT	CHECK	REMEDY
[10]	Defrost Heater	Open circuit	Correct
		Conductivity	
		Insulation resistance 1MΩ or more at 500V	Replace
[11]	Thermal Fuse	Conductivity	Replace
		Contact welding of relay	Replace relay
[12]	Supply Voltage	Check for ±6% of rated voltage	Increase power supply capacity Plug into a separate power receptacle
[13]	Refrigeration Circuit Clogged	Discharge pressure: High Suction pressure: Low (vacuum)	Replace capillary (Replace drier at same time)
[14]	Refrigerant Leak	Discharge pressure: Low	Locate leakage and replace (Replace drier at same time)
		Suction pressure: Low	
		Compressor discharge pipe will not heat up	Note: Low-side leak requires drying after welding
		Compressor suction pipe will not cool down	
Check with leak detector			
[15]	Air Filter	Clogged	Clean
	Air-Cooled Condenser	Dirty fins	
[16]	Drain Hose	Without trap structure, without hose	Connect drain hose with trap structure
[17]	Evaporation Pan Heater*	Open circuit	Correct or replace
		Conductivity	
[18]	Thermostat*	Open circuit	Correct or replace
		Conductivity	

\*Forced drain water evaporation models only

## 4. CONTROLLER

### [a] SERVICING CONTROLLER

- 1) When receiving a service call, ask the user to turn off the power supply and turn it back on after 30 seconds, while watching the unit. This will reset the controller, and in some cases normal operation will resume.
- 2) Keep the following in mind when servicing the controller:
  - \* Check that the unit has been earthed properly. If not, the controller will not work properly.
  - \* To get static free, always touch the cabinet (earth) before servicing. Electrostatic discharge will cause severe damage to the controller.
  - \* The controller and thermistor can be replaced separately.
  - \* Do not drop the controller on the floor.
  - \* The thermistor and pressure switch leads have a thin coating and are potentially breakable. Do not tension the leads.
  - \* The connectors must not be subjected to tension to prevent disconnection or breakage. After servicing the controller, check for disconnected connectors.
  - \* The thermistor is provided with single-wire leads. Do not bend or stretch them.
  - \* Do not pinch or weigh down the thermistor and thermistor leads. The coatings may be broken, resulting in a short circuit.

## [b] CHECKING THERMISTOR

- 1) Remove the thermistor from the controller.
- 2) Put ice and water in a glass or other container to make 0°C water. Immerse the thermistor bulb in the water for 5 minutes (at the center of the container).
- 3) Use the  $\Omega$  range of the tester to measure the resistance between the thermistors.
- 4) If the measured resistance is not within 25 - 30 k $\Omega$  (standard 27 k $\Omega$ ), replace the thermistor (see the T-R curve below).

### T-R Curve (Interior/Defrost Thermistor)

The graph shows reference values only and may differ from actual values.

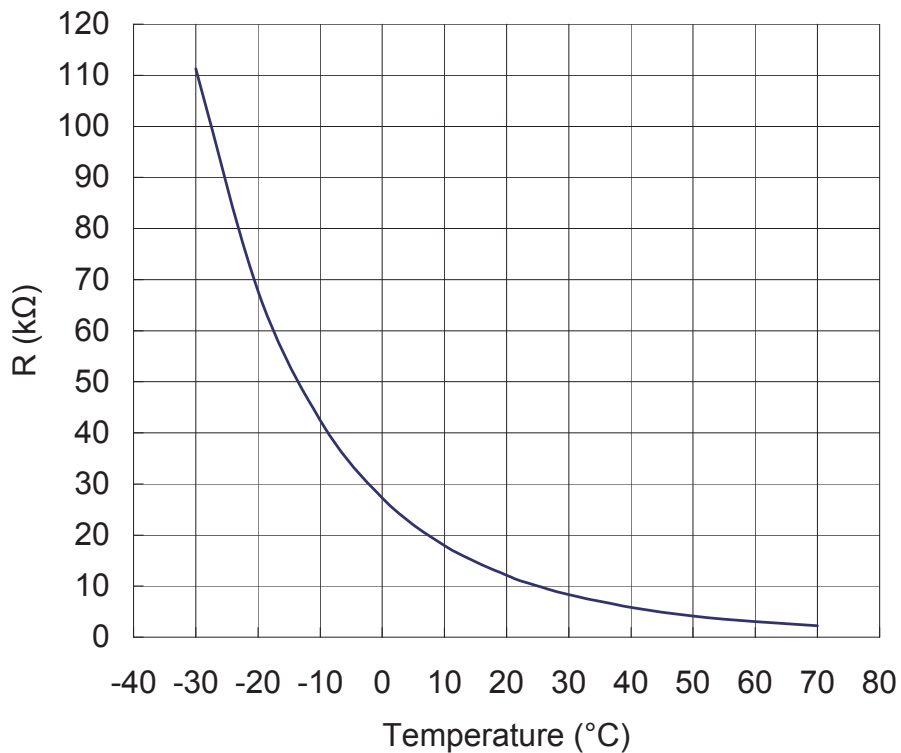

## IV. REMOVAL AND REPLACEMENT OF COMPONENTS

### WARNING

Always unplug the unit or turn off the main power supply before replacing components.

### 1. REFRIGERATION CIRCUIT

#### [a] REFRIGERANT

Refrigerant R134a used for this unit is not flammable or poisonous itself. It also provides remarkably lower pressure than ammonia or similar substances at the same condensing temperatures.

#### [b] COMPRESSOR

- 1) Remove the hexagon head bolt at the bottom of the front panel, and take off the front panel.
- 2) Recover the refrigerant from the access valve, and store it in a proper container, if required by an applicable law.
- 3) Remove the screws securing the condenser to the refrigeration unit base and the shroud (condenser cover) to the cabinet, and pull out the condenser about 200 mm to the front.

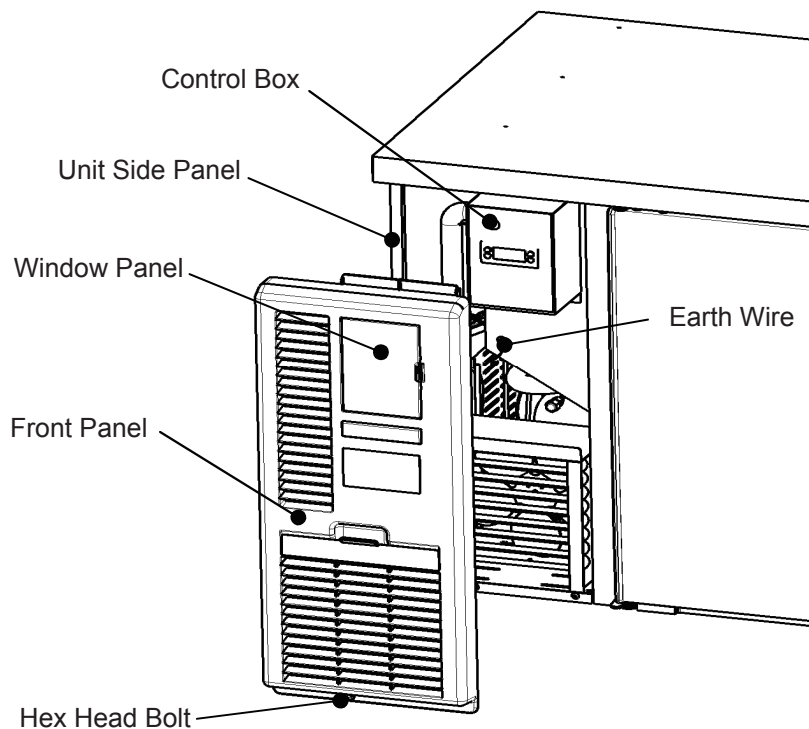

- 4) Remove the hexagon head bolts with washers securing the condenser fan motor bracket to the base, and remove the condenser fan motor assembly.
- 5) Remove the screw securing the unit side panel, and take off the side panel.
- 6) Remove the terminal cover enclosing the compressor electrical parts.
- 7) Remove the overload relay and start relay.
- 8) Disconnect the discharge and suction pipes using brazing equipment.
- 9) Remove the bolts securing the compressor.
- 10) To replace the removed parts, reverse the above removal procedure.

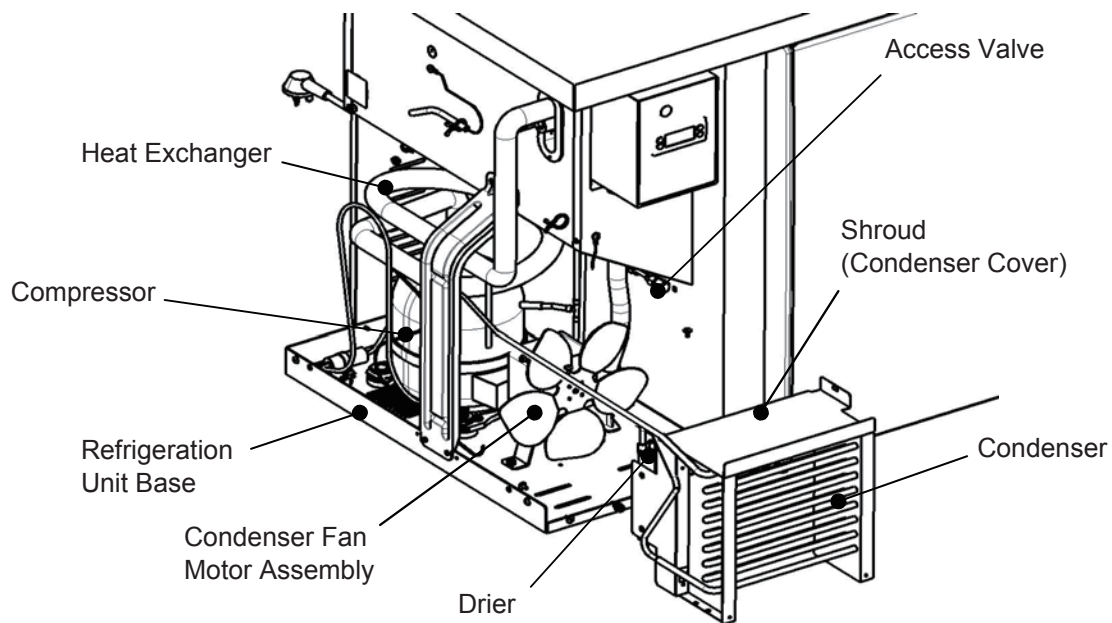

- Note:
1. To recharge the refrigerant, install a stop valve in the access line.
  2. Evacuation time must be at least 1 hour.
  3. To prevent oxidation, braze the pipes with nitrogen gas flowing.
  4. Check for gas leaks, remove flux and oxide film, and apply anti-corrosion treatment.
  5. While brazing, use a wet towel to protect the plastic parts and electrical parts from burner flame.

### **[c] CONDENSER**

- 1) Pull out the condenser according to steps 1) through 3) of “[b] COMPRESSOR”.
- 2) Remove the screws securing the shroud to the condenser, and disconnect the shroud.
- 3) Disconnect the condenser from the refrigeration circuit using brazing equipment. Use a wet towel to protect any flammable materials from burner flame.
- 4) To replace the removed parts, reverse the above removal procedure.

Note: See Notes 1 - 5 for “[b] COMPRESSOR”.

### **[d] DRIER**

- 1) Pull out the condenser according to steps 1) through 3) of “[b] COMPRESSOR”.
- 2) Remove the wire tie securing the drier to the shroud.
- 3) Disconnect the drier from the refrigeration circuit using brazing equipment. Use a wet towel to protect any flammable materials from burner flame.
- 4) To replace the removed parts, reverse the above removal procedure.

Note: 1. See Notes 1 - 5 for “[b] COMPRESSOR”.

2. After brazing, wait for the drier to cool down before securing it to the shroud.

### **[e] EVAPORATOR**

- 1) Remove the front panel.
- 2) Unscrew the top and bottom of the control box to remove the control box.
- 3) Remove the unit side panel.
- 4) Recover the refrigerant from the access valve, and store it in a proper container, if required by an applicable law.
- 5) Disconnect the evaporator from the heat exchanger (first from the suction pipe and then from the capillary tube) using brazing equipment. Use a wet towel to protect any flammable materials from burner flame.
- 6) Remove the intake and exhaust ducts from inside the cabinet.
- 7) Remove the interior fan motor assembly.

- 8) Remove the evaporator cover (and the heater cover with the heater bracket).
- 9) Remove the defrost thermistor from the evaporator.
- 10) To replace the removed parts, reverse the above removal procedure.

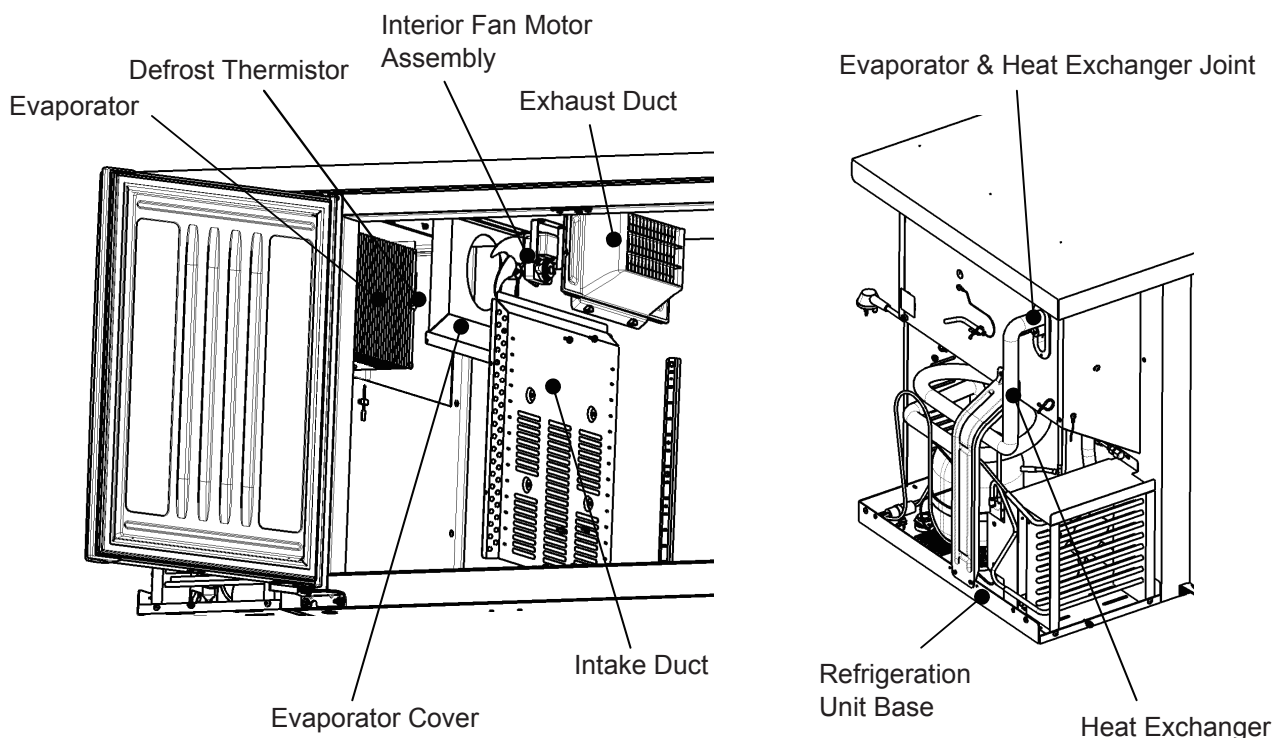

Note: 1. See Notes 1 - 5 for “[b] COMPRESSOR”.

2. Be sure to replace the defrost thermistor in its correct position.
3. After servicing, use putty to seal the pipe through-hole in the cabinet.
4. When disconnecting the evaporator from the heat exchanger, use a wet towel to protect the wires from burner flame.

## 2. ELECTRICAL PARTS

### [a] CONDENSER FAN MOTOR

- 1) Pull out the condenser and condenser fan motor assembly according to steps 1) through 4) of “[b] COMPRESSOR”.
- 2) Disconnect the condenser fan motor leads.
- 3) Remove the screws securing the condenser fan motor to the bracket, and take off the condenser fan motor.
- 4) To replace the removed parts, reverse the above removal procedure.



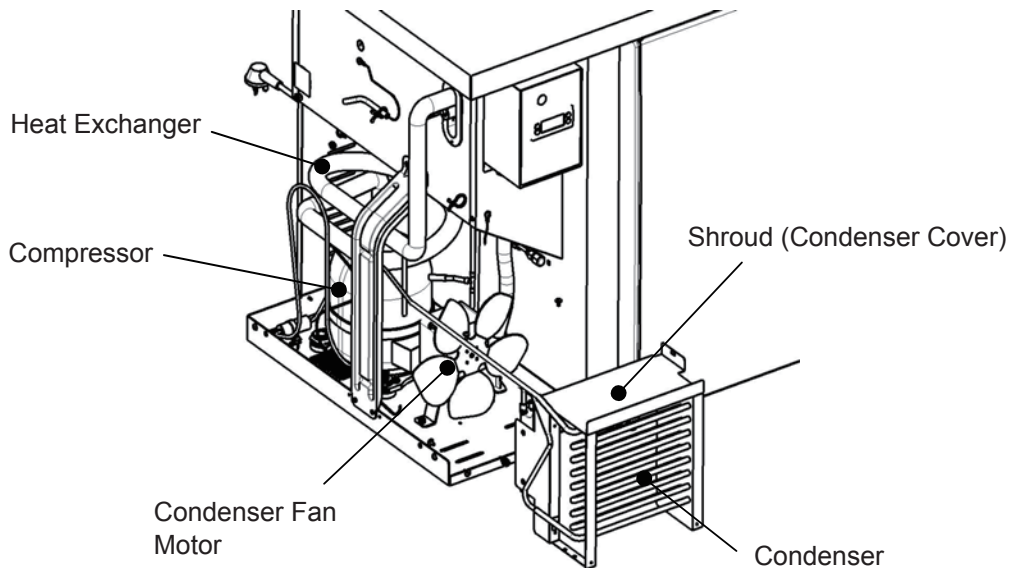

**[b] INTERIOR FAN MOTOR**

- 1) Remove the front panel.
- 2) Disconnect the interior fan motor leads.
- 3) Remove the intake and exhaust ducts from inside the cabinet.
- 4) Remove the insulations in the wire through-hole from inside and outside the cabinet.
- 5) Remove the interior fan motor assembly.
- 6) Remove the screws securing the interior fan motor to the bracket, and take off the interior fan motor.
- 7) To replace the removed parts, reverse the above removal procedure.

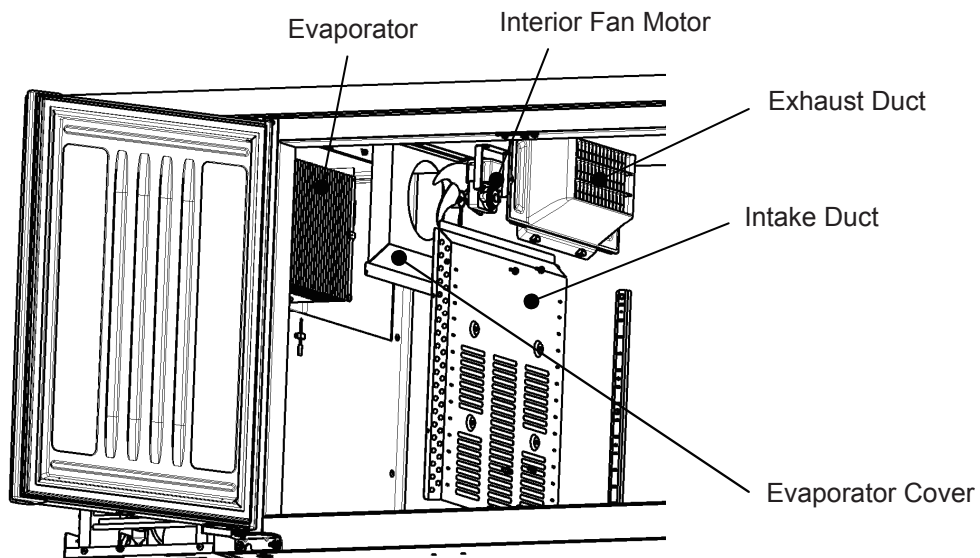

- Note: 1. After servicing, insert new insulations into the wire through-hole from inside and outside the cabinet. Do not reuse the removed insulations.
2. Be sure to install the interior fan motor in the proper direction as shown above.

### [c] DEFROST HEATER, THERMAL FUSE

- 1) Remove the front panel.
- 2) Disconnect the defrost heater or thermal fuse leads.
- 3) Remove the intake duct and exhaust duct from inside the cabinet.
- 4) Remove the insulations in the wire through-hole from inside and outside the cabinet.
- 5) Remove the defrost heater and thermal fuse with the heater cover and bracket from the evaporator.
- 6) Bend the heater holder on the heater cover to remove the defrost heater from the heater cover. Take off the clip to remove the thermal fuse.
- 7) Pull the leads out of the wire through-hole to remove the defrost heater or thermal fuse.
- 8) To replace the removed parts, reverse the above removal procedure.

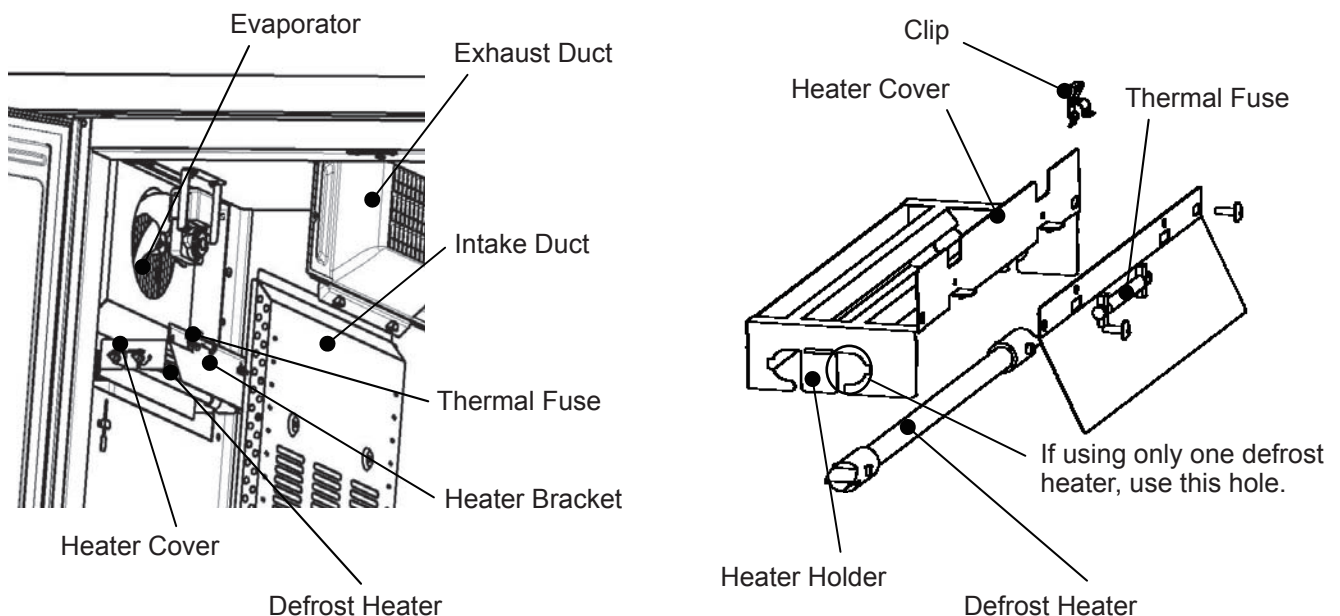

- Note: 1. After servicing, insert new insulations into the wire through-hole from inside and outside the cabinet. Do not reuse the removed insulations.

2. If using two defrost heaters, mark the end of the heater leads to prevent miswiring.
3. If using only one defrost heater, install the heater in the hole on the cabinet side of the heater cover.

#### [d] INTERIOR THERMISTOR, DEFROST THERMISTOR

- 1) Remove the front panel.
- 2) Disconnect the interior thermistor or defrost thermistor leads.
- 3) Remove the intake duct and exhaust duct from inside the cabinet.
- 4) Remove the insulations in the wire through-hole from inside and outside the cabinet.
- 5) Open the plastic clamp to remove the interior thermistor. Pull the thermistor clip off the evaporator to remove the defrost thermistor.
- 6) To replace the removed parts, reverse the above removal procedure.

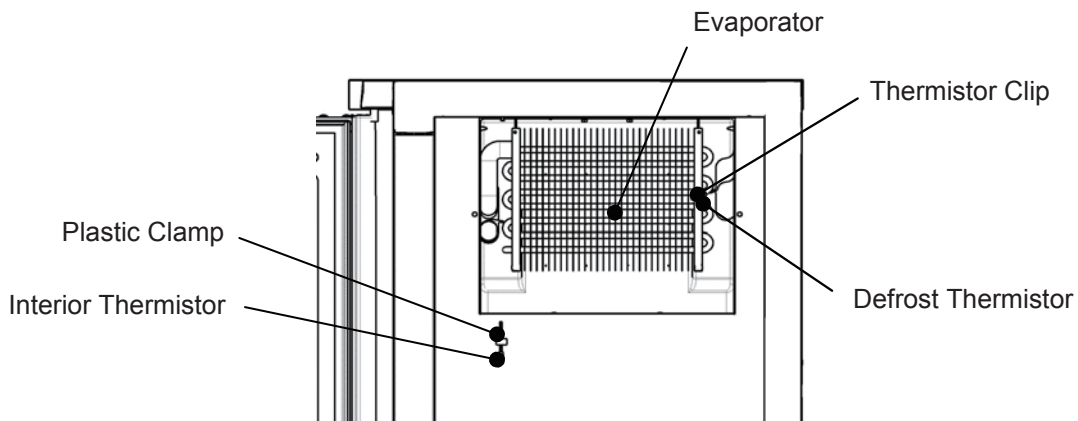

- Note: 1. After servicing, insert new insulations into the wire through-hole from inside and outside the cabinet. Do not reuse the removed insulations.
2. Be careful not to contact the interior thermistor bulb on the cabinet interior wall.
  3. Route the defrost thermistor leads through the U-channel at the evaporator top out of the evaporator reed pipe side.
  4. If the defrost thermistor color is not white, wind white vinyl tape around the thermistor as shown below for indication.

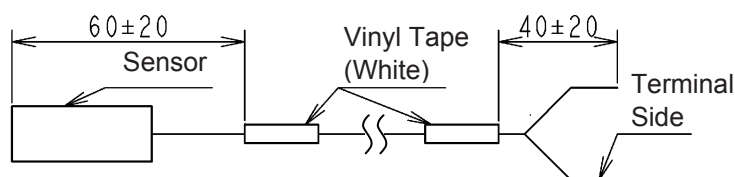

## [e] CONTROLLER

- 1) Remove the front panel.
- 2) Unscrew the top and bottom of the control box to remove the control box.
- 3) Push the stoppers at both sides of the controller, and slide the stoppers to remove the controller.
- 4) Use a precision flat head screwdriver to loosen the screws and disconnect the wiring from the controller.
- 5) To replace the removed parts, reverse the above procedure.

## [f] FUSE

- 1) Open the window panel.
- 2) Apply a flat head screwdriver to the slot on the fuse holder and turn it counterclockwise.
- 3) Remove the fuse from the fuse holder.
- 4) To replace the removed parts, reverse the above procedure.

## [g] FORCED DRAIN WATER EVAPORATION PAN (Forced drain water evaporation model only)

- 1) Remove the front panel.
- 2) Remove the side panel of the refrigeration unit.
- 3) Disconnect the connector at the end of the evaporation pan lead wire.
- 4) Put the evaporation pan lead wire and connector through the wire hole to the outside of the machine compartment.
- 5) Remove the four screws at the bottom of the unit to take off the evaporation pan.
- 6) To replace the removed parts, reverse the above removal procedure.

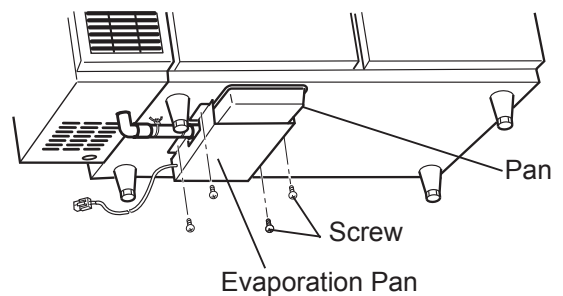
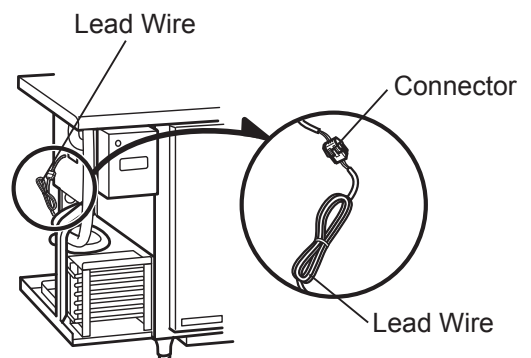

### 3. DOOR GASKET

#### [a] REMOVAL

- 1) Open the door.
- 2) Detach the door gasket from the door liner.

#### [b] REPLACEMENT

- 1) Spray water on the door liner channel with a sprayer.
- 2) Fit the four corners of the door gasket into those of the door liner channel.
- 3) Push in each part of the door gasket from both sides.

Note: After fitting the door gasket, check every part for tightness and security.

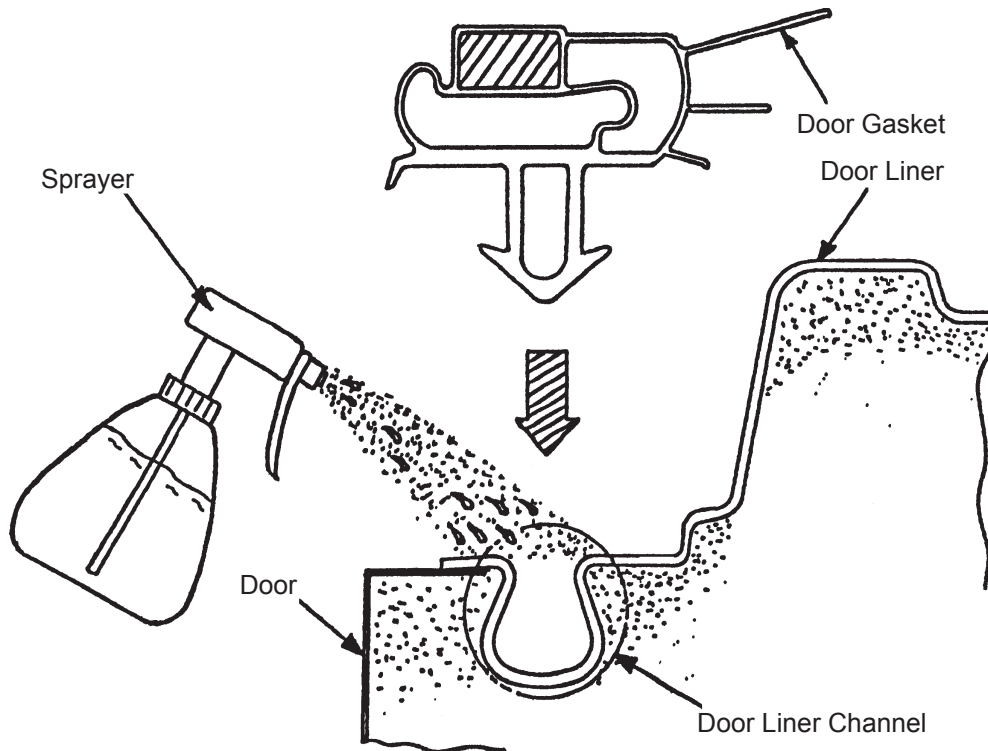

Replacement of the door or door gasket may cause a gap between the cabinet and the gasket. To correct this gap, slightly heat the gasket with a drier. To avoid melting the gasket:

- 1) Keep the drier at least 100 mm away from the gasket.
- 2) Move the drier up and down to heat the entire gap.

Note: If the drier is too close or heats a particular part intensively, the gasket may melt.

